

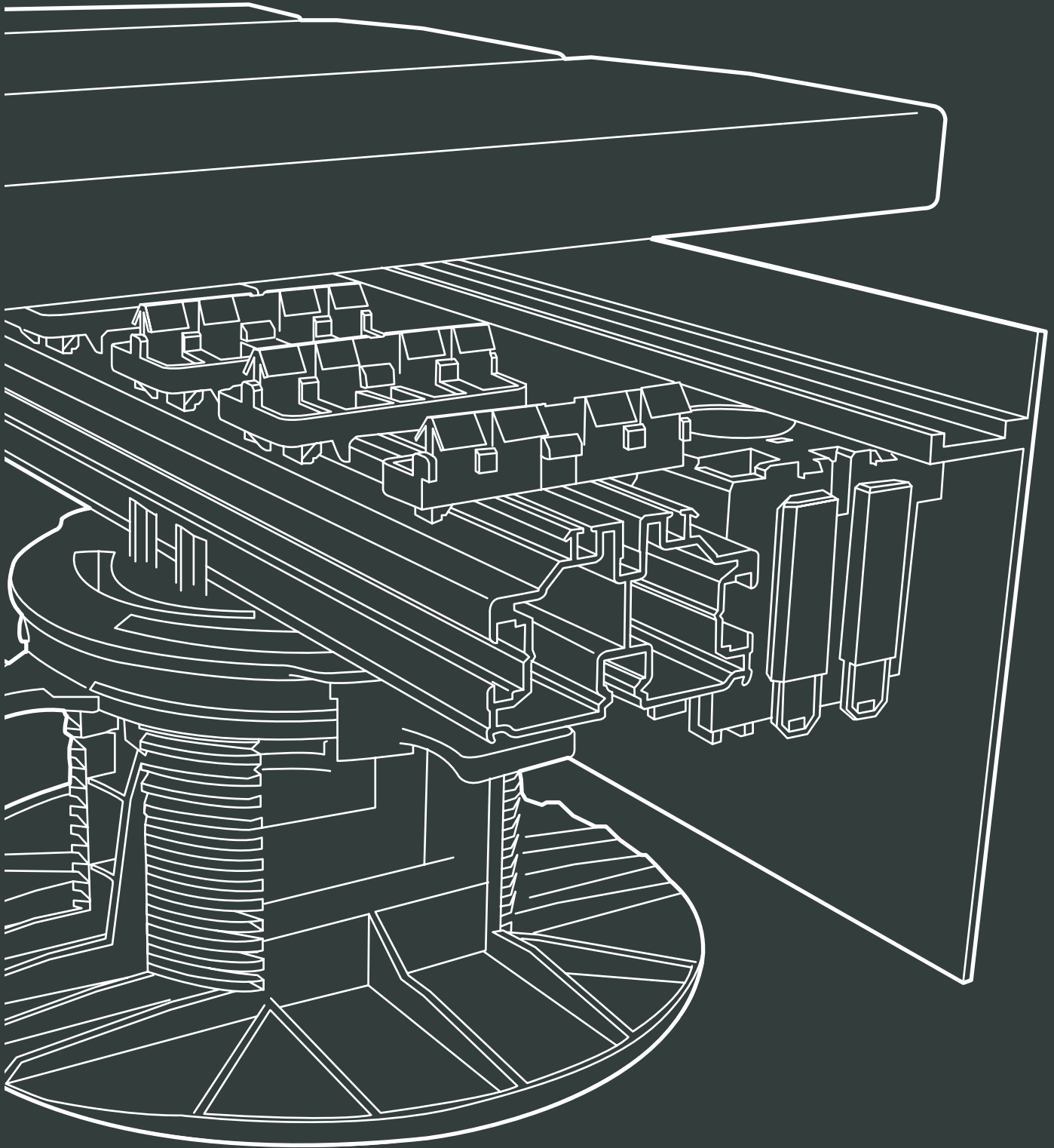

Installation guide

PR39/PR56 Decking on Top
Lift Pedestals with Aluminum
Skirting Finish





FOREWORD

Design your outdoor space quickly and easily with the Grad® decking system.

This installation guide will walk you through the simple step-by-step process of building a Grad deck using PR39/56 support rails on pedestals, and finished with aluminum skirting.

CONTENTS

→ 01 Step-by-step construction	4
Before you start	5
Defining the dimensions of your deck	6
Preparing and cutting the rails	8
Positioning the pedestals	10
Top Cube installation	11
Positioning the perimeter rails	13
Assembling the structure	14
Adapting the structure to a door threshold	15
Aligning and levelling the structure	16
Preparing and mounting aluminium skirting	18
Adding Clip Grips	22
Cutting and positioning the boards	23
→ 02 How to easily remove a decking board	26
Dismantling Keys	27

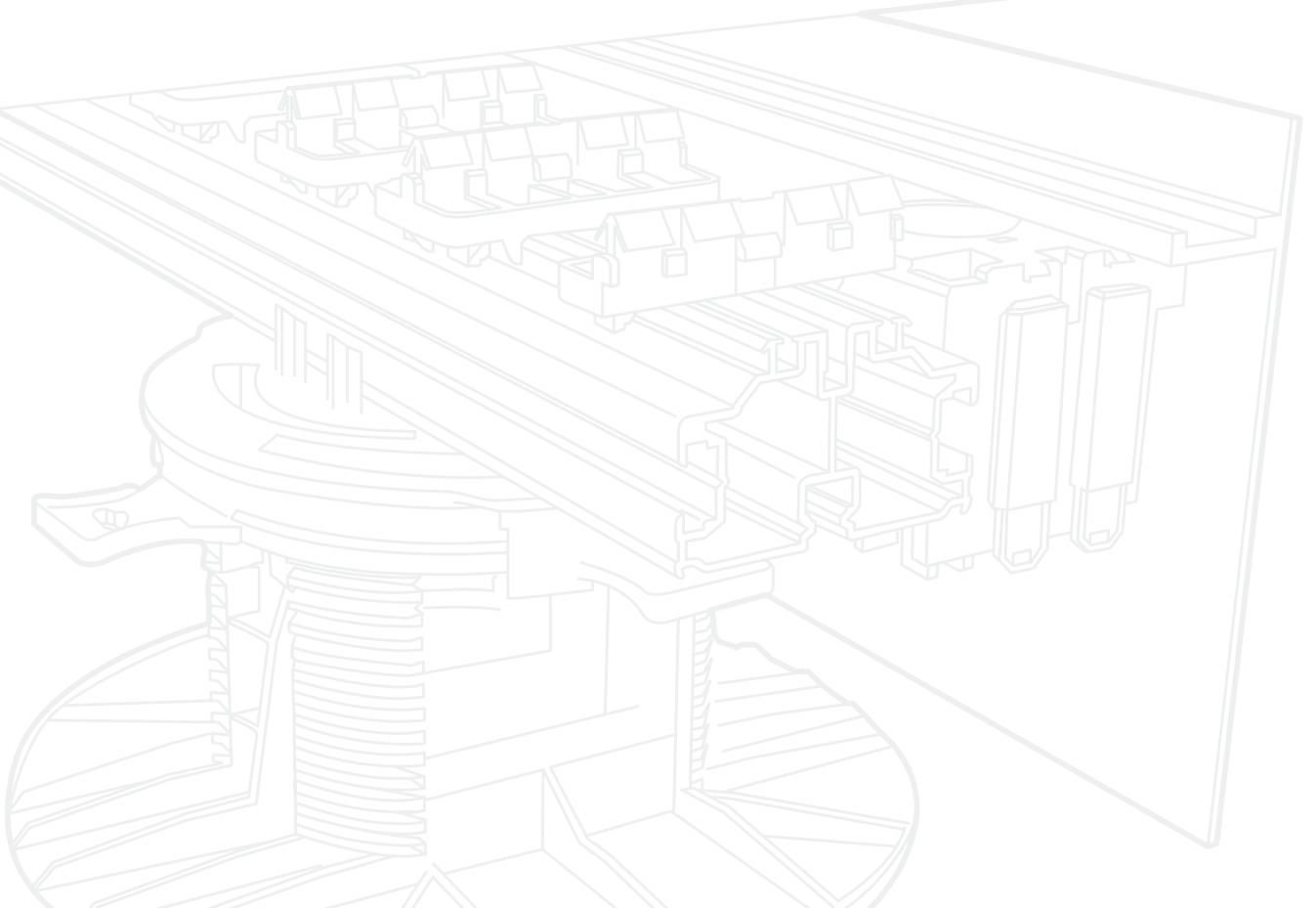

PR39/PR56 DECKING ON TOP LIFT PEDESTALS

Installation guide

From preparing the rails to positioning the boards, including the mounting of aluminium skirting.



Before you start

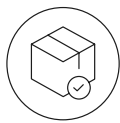

Delivery of Grad products®

Make sure that everything is as you ordered. Have all the products been delivered? Are they in good condition?



If this is not the case, set aside the damaged items at the time of delivery and contact our customer service department.



Precautions

Before starting the installation, ensure that the ground is stable and that there is no live electrical wiring in the installation area.



Personal Protective Equipment

To avoid injury, we recommend you wear protective clothing and safety equipment such as gloves and goggles. The latter are essential, especially when cutting aluminium rails and wooden boards.



Grad® accepts no responsibility for any failure to comply with the safety instructions.



Tools

Here is a non-exhaustive list of recommended tools for installing a deck with PR39/56 rails on pedestals with aluminum skirting.



*TX 20-25-30
drill/driver bit*



Radial saw with mixed wood/aluminium disc



Spirit level



Wrench 13



Meter



Cutter



Mason's ruler



White marker/pencil

1 Define the dimensions of the deck

Dimension X

Without skirting

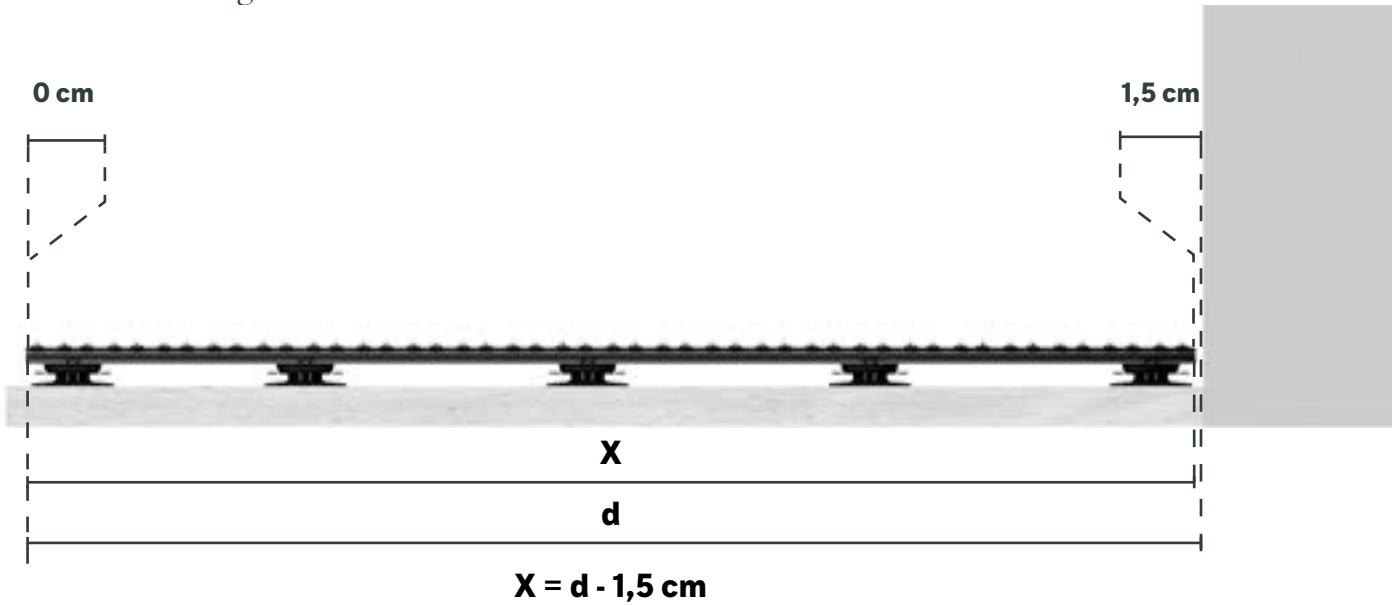

With aluminium skirting

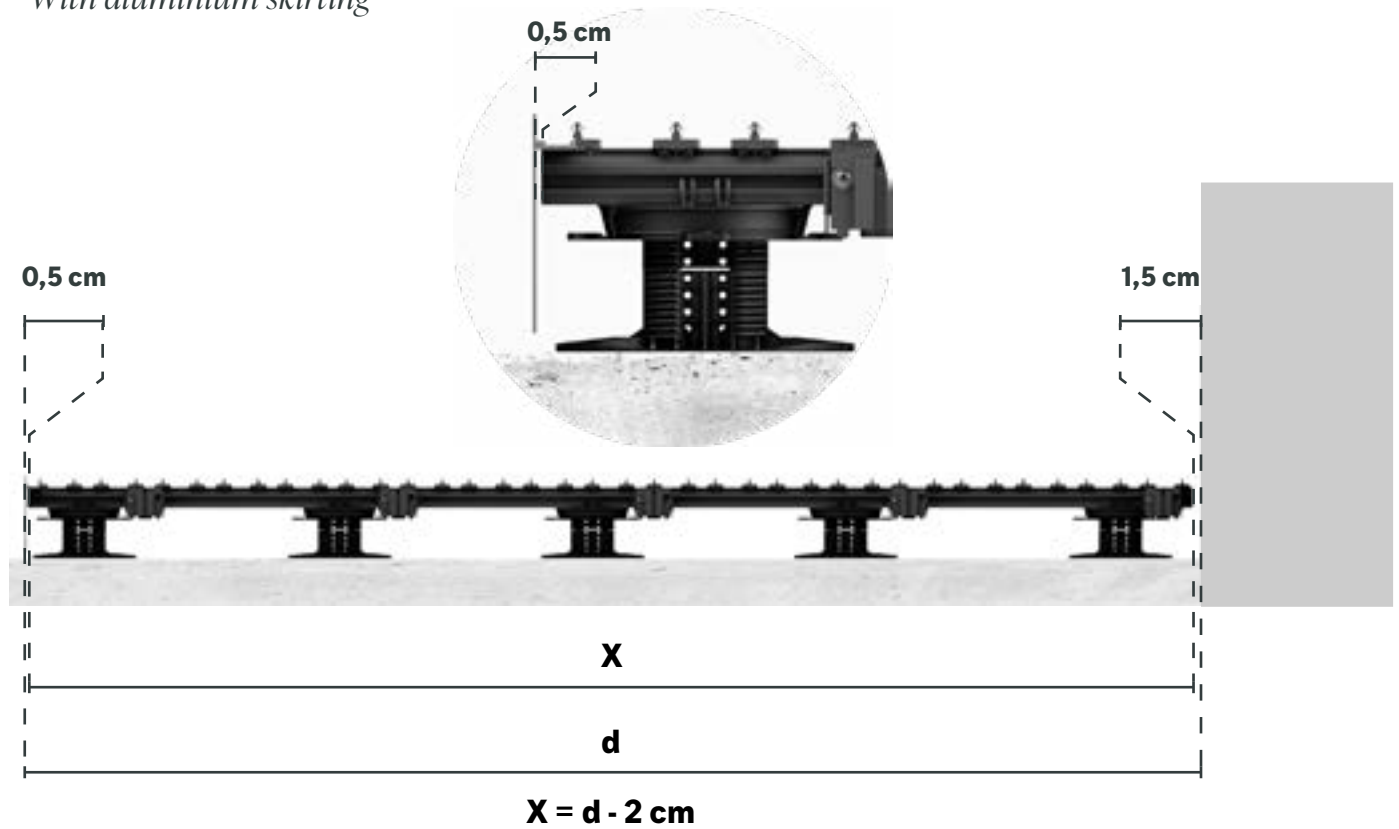

Why is the cut rail on the wall side?

When it is necessary to cut a rail between two clips, we recommend positioning this section against a wall for a better aesthetic result.

7 PR39/PR56 DECKING ON TOP LIFT PEDESTALS

Dimension Y

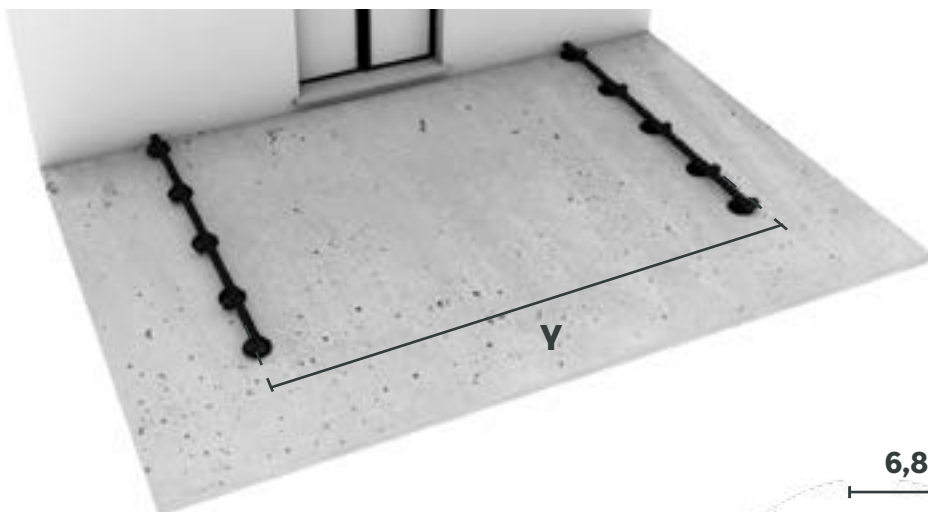

Without skirting

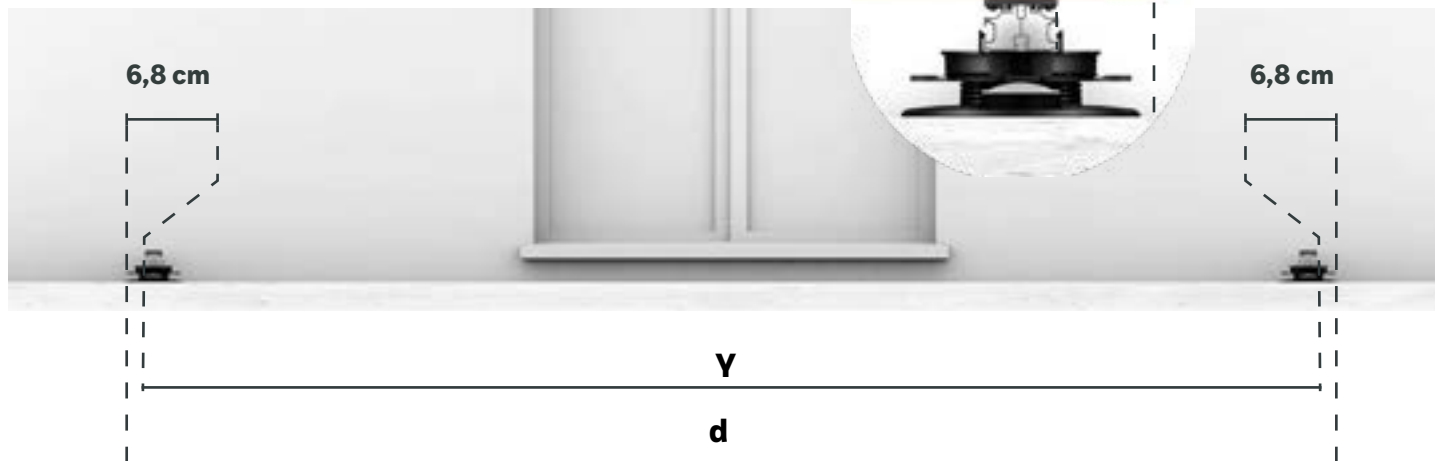

$$Y = d - (2 \times 6,8 \text{ cm}) = d - 13,6 \text{ cm}$$

With aluminium skirting

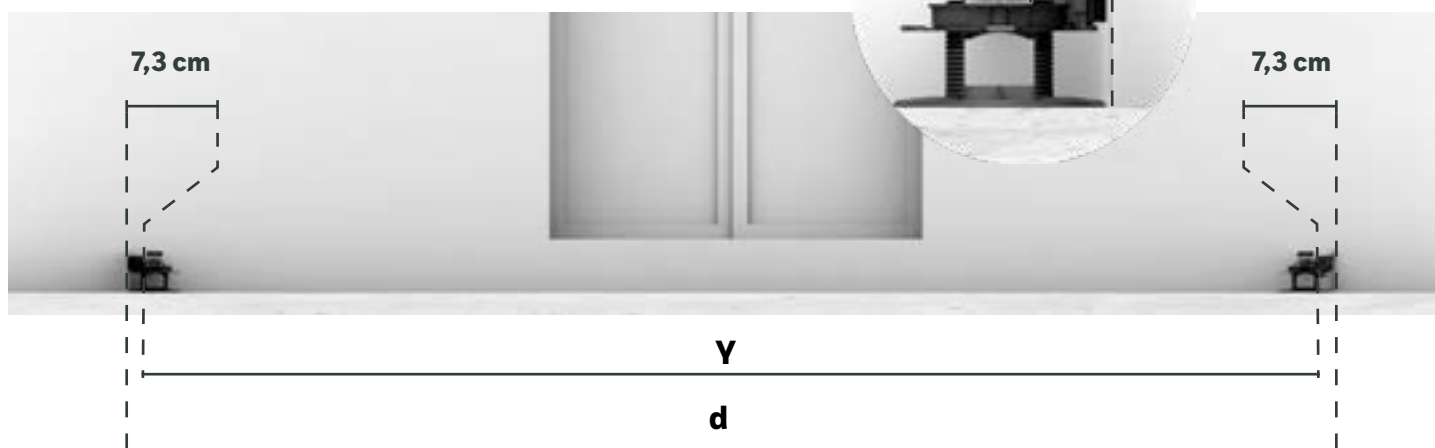

$$Y = d - (2 \times 7,3 \text{ cm}) = d - 14,6 \text{ cm}$$

2 Preparing and cutting the rails

1. Cutting the rails



Recommended PPE



 For an optimal rail cut, you can trim it so that it does not protrude more than one board (fig.1). If you cannot cut it this way, you will need to cut your rail, cut the board, and use a wedge clip (fig.2).

 Never cut a clip that is engaged on a rail. If you need to make a cut where there is a clip, be sure to first remove the Grad® clip before cutting.

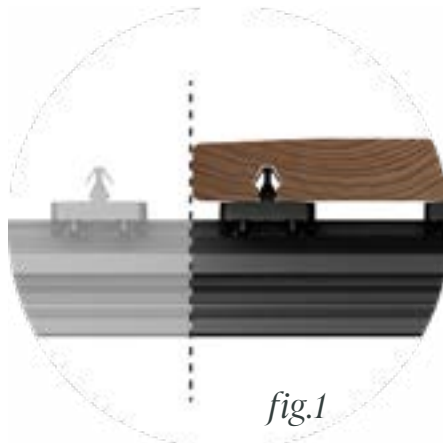

fig.1

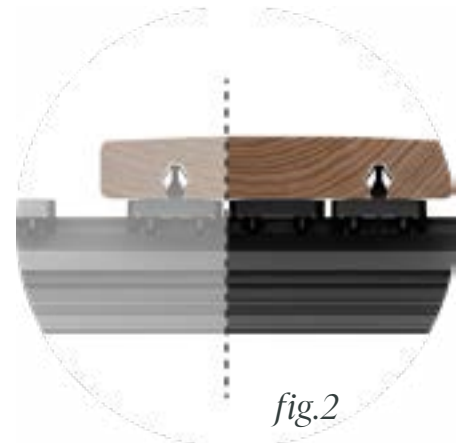

fig.2

2. Removing the clip/adding the half-clip

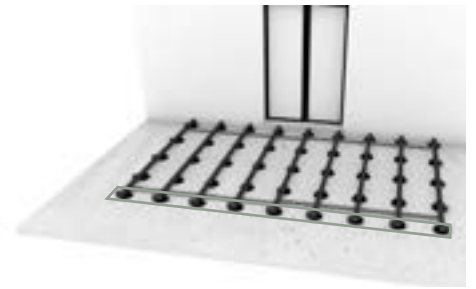

fig.1



Remove the last clip from each rail so that the aluminium skirting can be mounted. To remove the clip, follow the procedure described on p.28.

3,3 cm max.



SCAN ME!



To fit the half-clip, simply position the clip so that the lugs engage in the perforated sections of the rail and apply vertical pressure with 2 fingers.

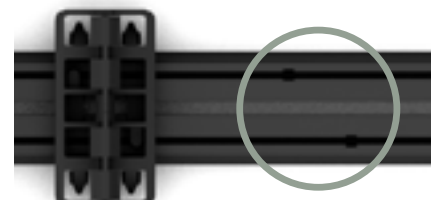
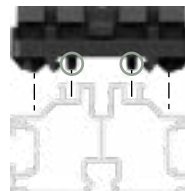

3 Assemble and position the Top Lift pedestals



Adjust the pedestal

If you are adding boosters and stabilisers, it is easier to remove the top part of the pedestal and replace it once the accessories are in place. To do this, make sure that the various components are correctly positioned.



SCAN ME!



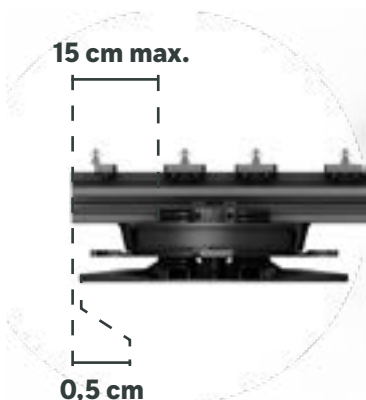
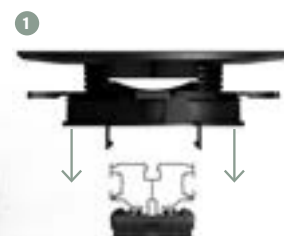
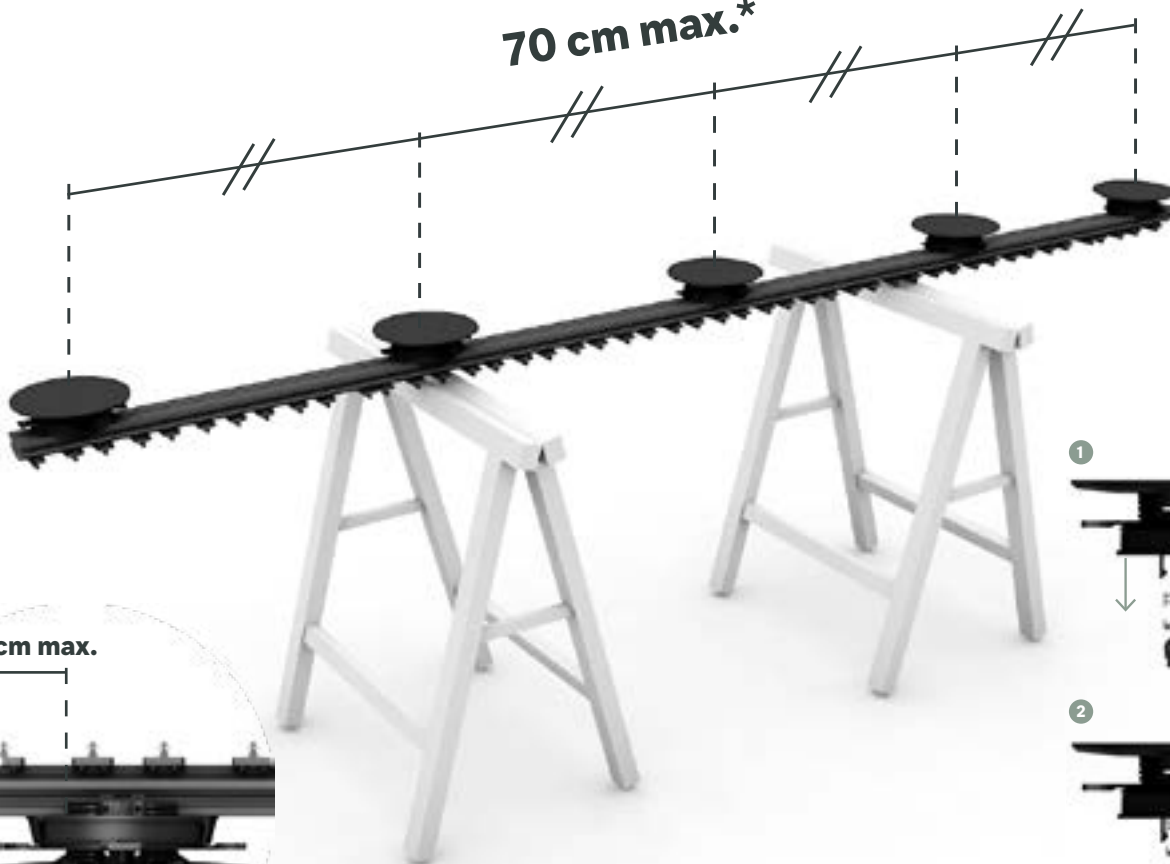

70 cm max.*

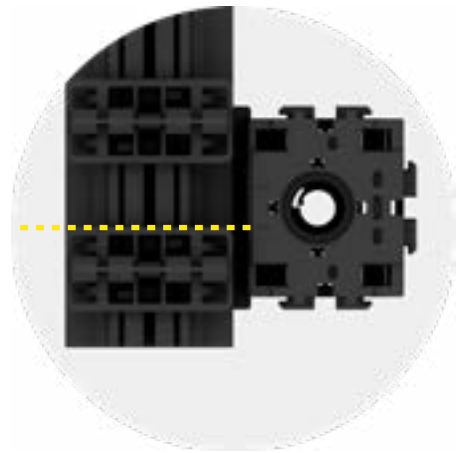
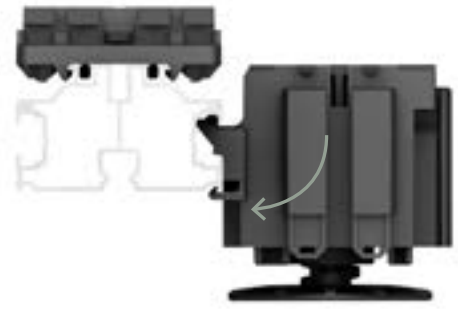

*depending on category of use and profile. If you have any questions, please contact Grad® customer service.

4 Installing Top Cubes



 If you want to mount aluminium skirting you will need to install Top Cubes. The mini-pedestal is not necessary in this case and can be removed.

1. Position the Top Cubes

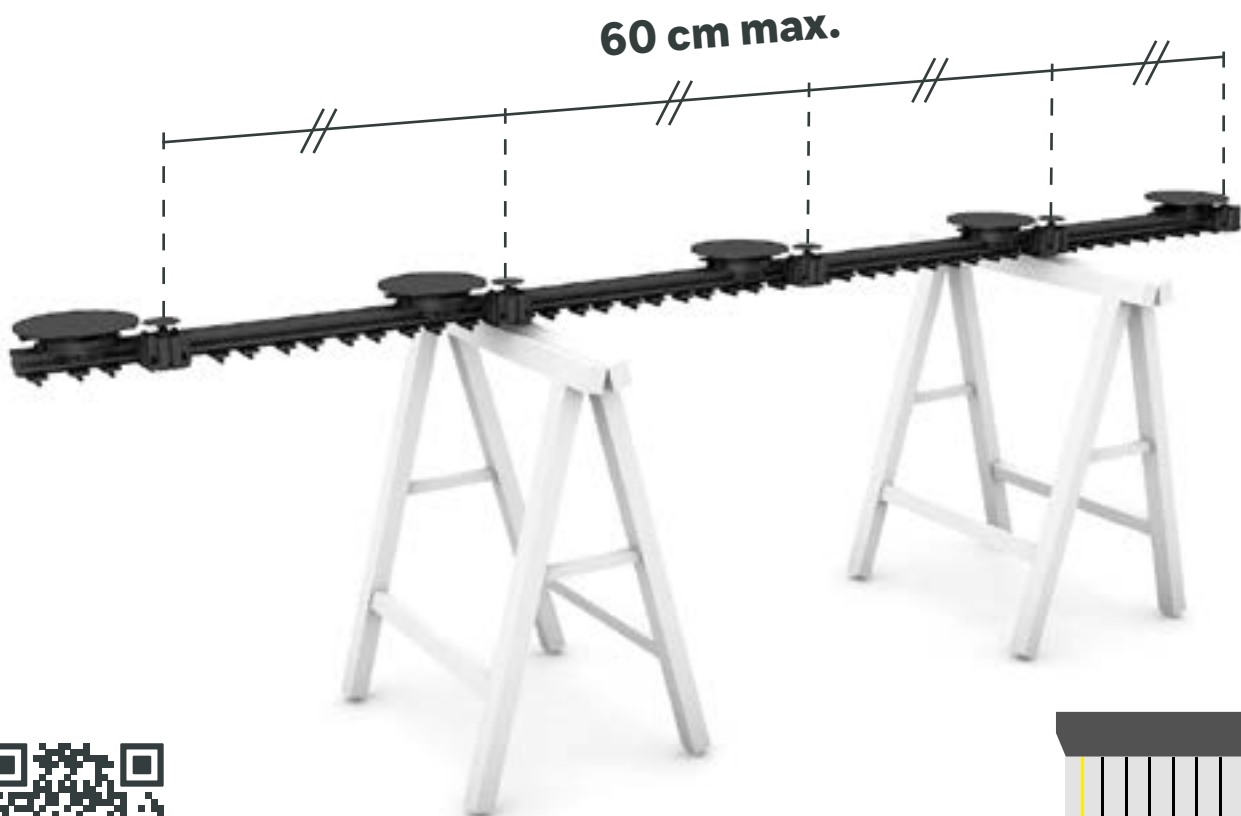

SCAN ME!

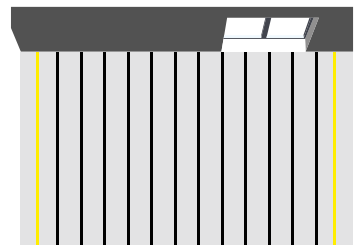

2. Fasten the Top Cubes



*Driver bit
TX30*



Although the Top Cube has two holes, only one screw is needed to secure it. Make sure that the arrow on the top of the Top Cube is aligned with the edge of the clip (see diagram p.11).

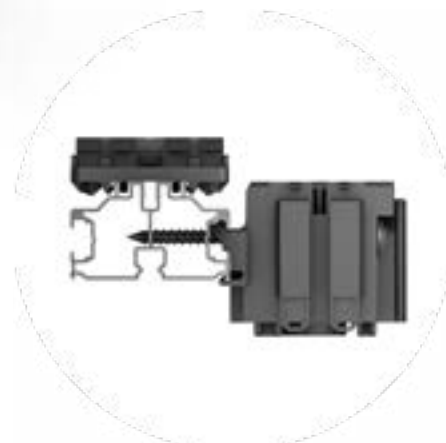

5 Position the outer rails

Dimension Y

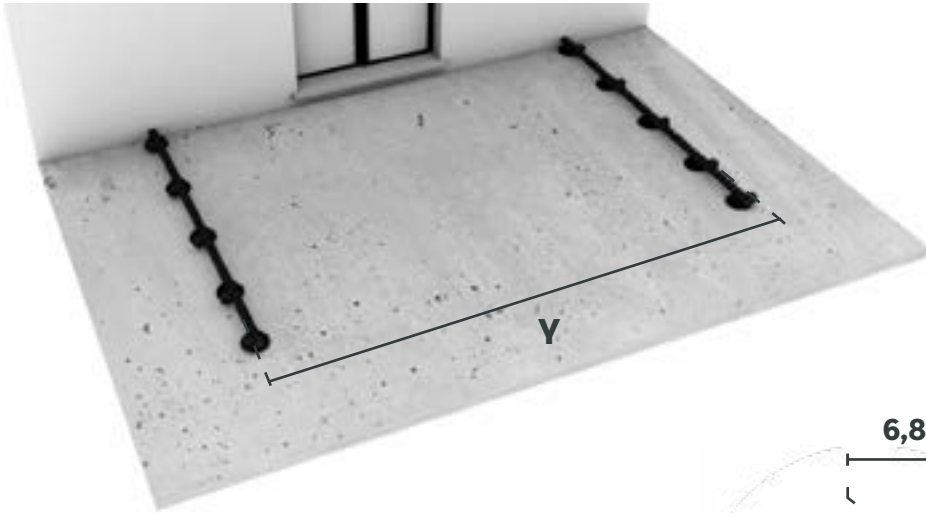

Without skirting

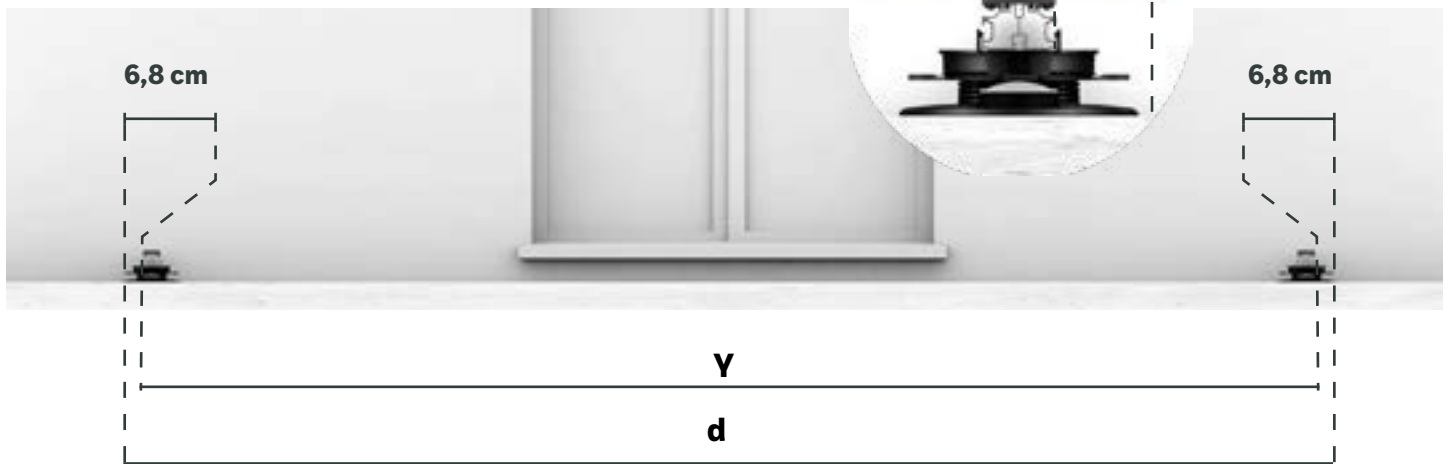

$$Y = d - (2 \times 6,8 \text{ cm}) = d - 13,6 \text{ cm}$$

With skirting

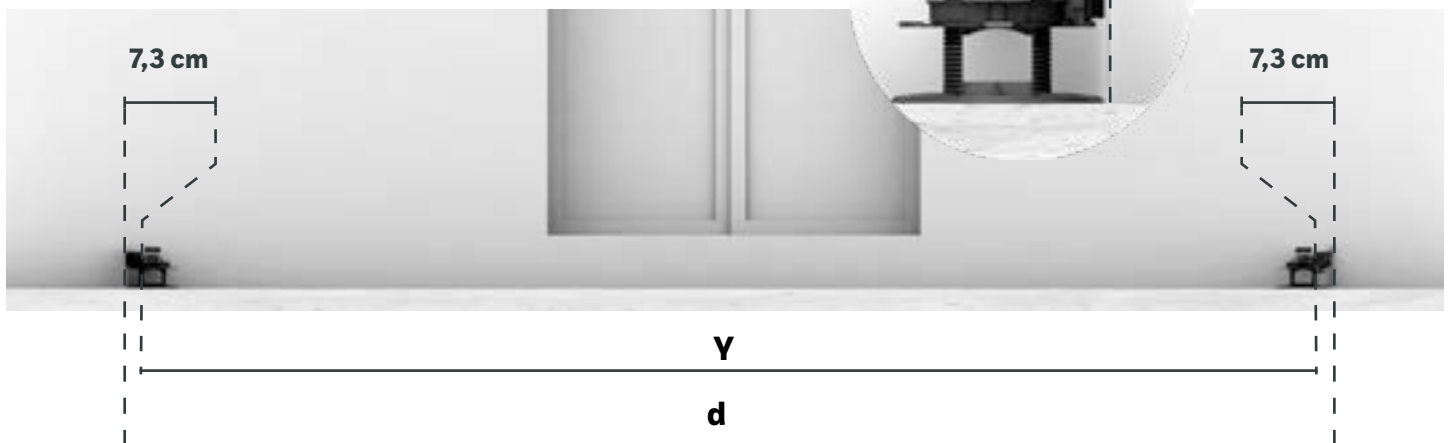

$$Y = d - (2 \times 7,3 \text{ cm}) = d - 14,6 \text{ cm}$$

6 Assembling the structure

Installing spanners

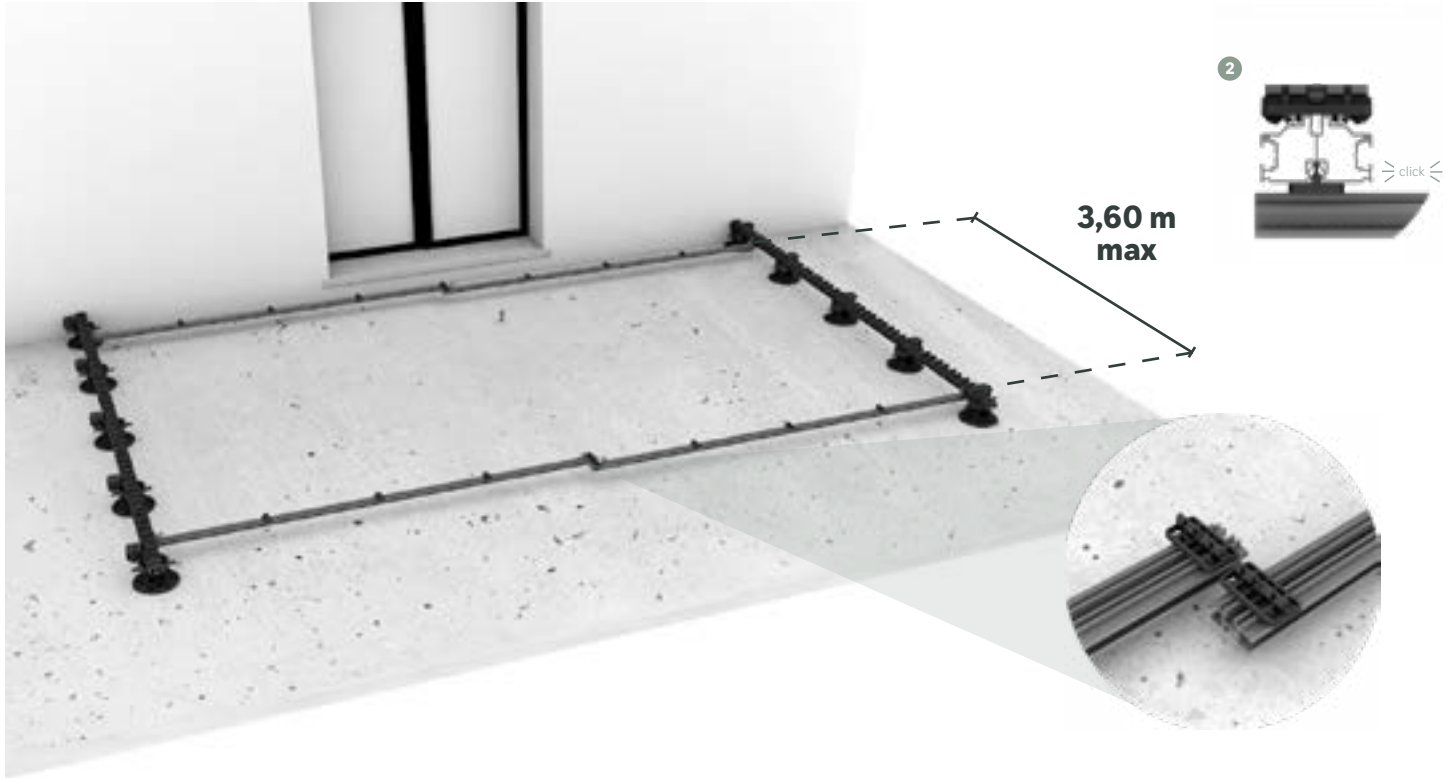

Positioning and securing the inner rails

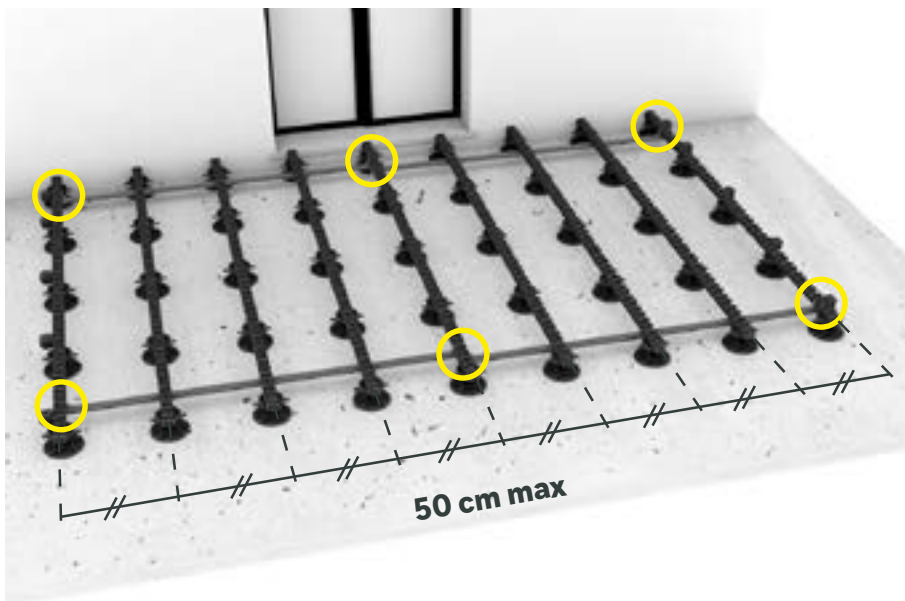

with PR39

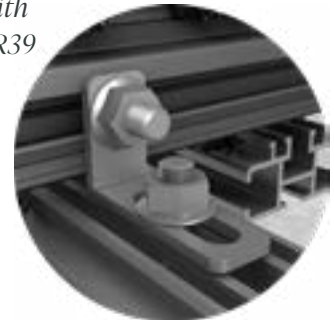

with PR56

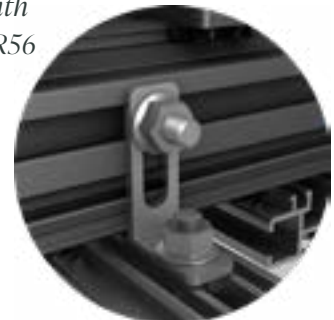

 The centre-to-centre distance, i.e. the space between the rails, varies according to the choice of decking boards and the use category of your deck.
If you have any questions, please contact Grad® customer service.

 Secure the rails and spanners.
Do not tighten the brackets yet.

Butt-jointing rails, if necessary

For private projects

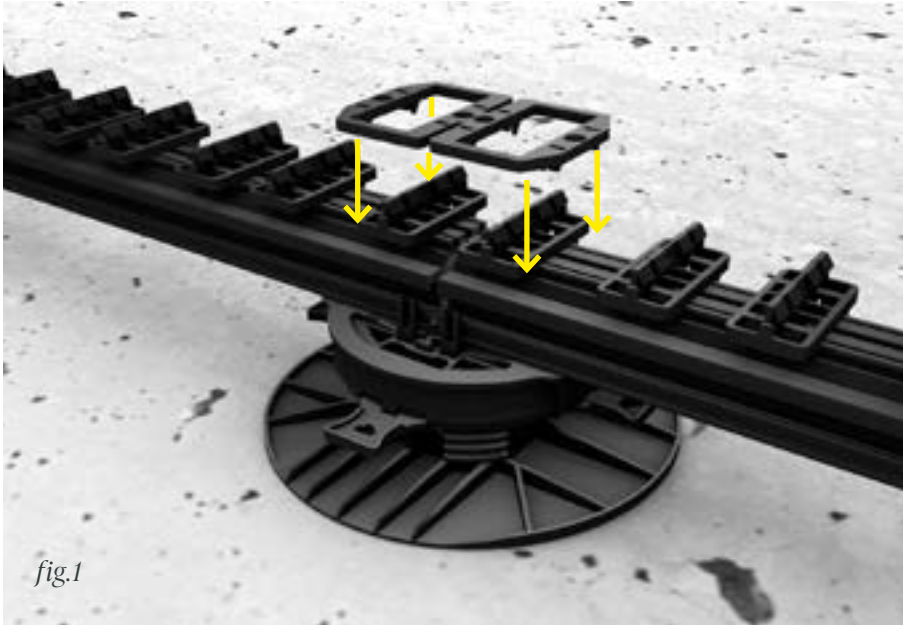

If the length of the rail is insufficient, you will need to butt-joint the rails.

To guarantee that the rails are spaced correctly, use Top Link joining pieces.

Butt joints should always be made over a pedestal.

For public projects

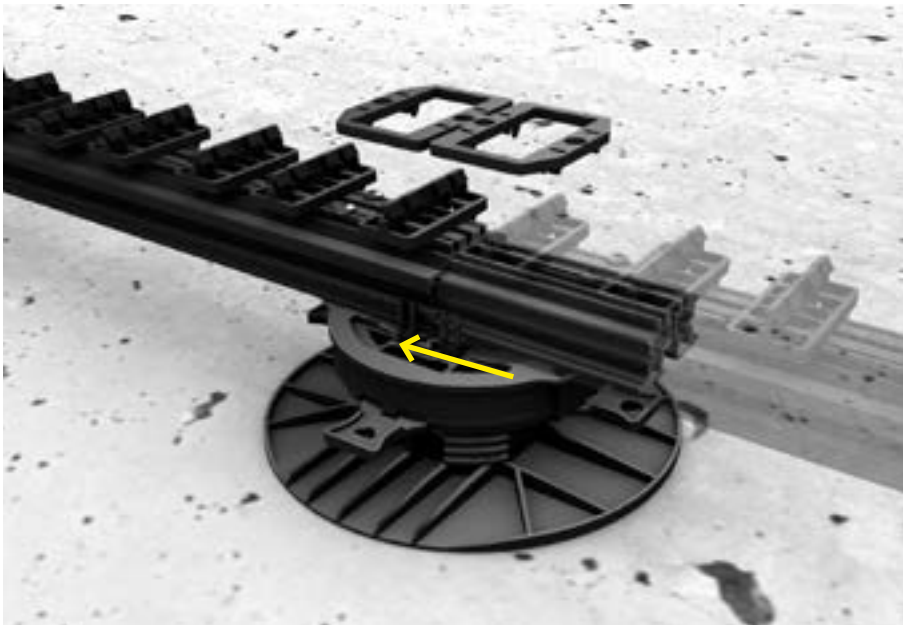

For public projects, the rail joints must be reinforced with aluminium joint bars.

A Top Link should be used and the butt joint should always be made over a pedestal.



Installing the joint bars

1. Insert the aluminium joint bars half-way into the rail, then secure them by screwing into the upper grooves of the rail at least 20 mm from the clip. There is no need to pre-drill.
2. Slide the second rail onto the joint bars. Set the distance using a Top Link. Once in place, secure the joint bars as you did in step 1.

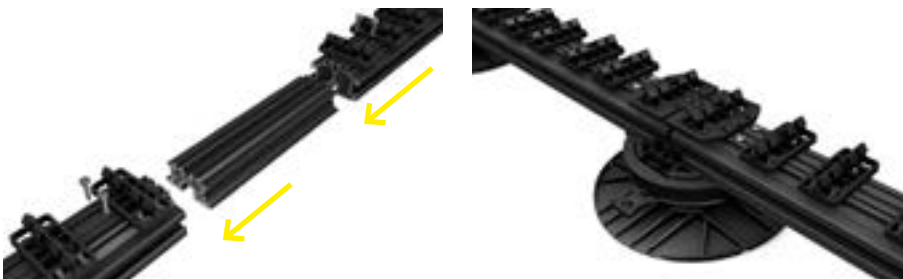

7 Adapting the structure to a door frame

1 Preparing the Flat Rails

As the Flat Rail is fitted directly onto the threshold, the rail must be fitted with an elastomer band.



2 Positioning and butt joining the Flat Rails



To ensure that the boards on the threshold are secure, Flat Rails must be placed no more than 10 cm from the edge of the wall. This is why a Flat Rail is placed on the right in this example, without being joined to a PR39/56. This Flat Rail should be slightly longer, with its clips aligned with the clips on the other Flat Rails and PR39/PR56 rails.

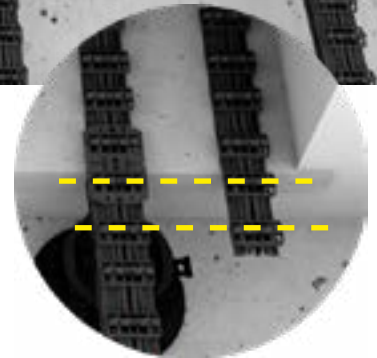

8 Aligning and levelling the structure

Alignment

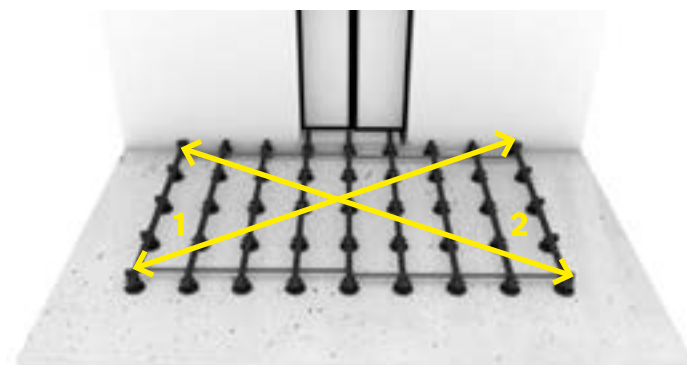
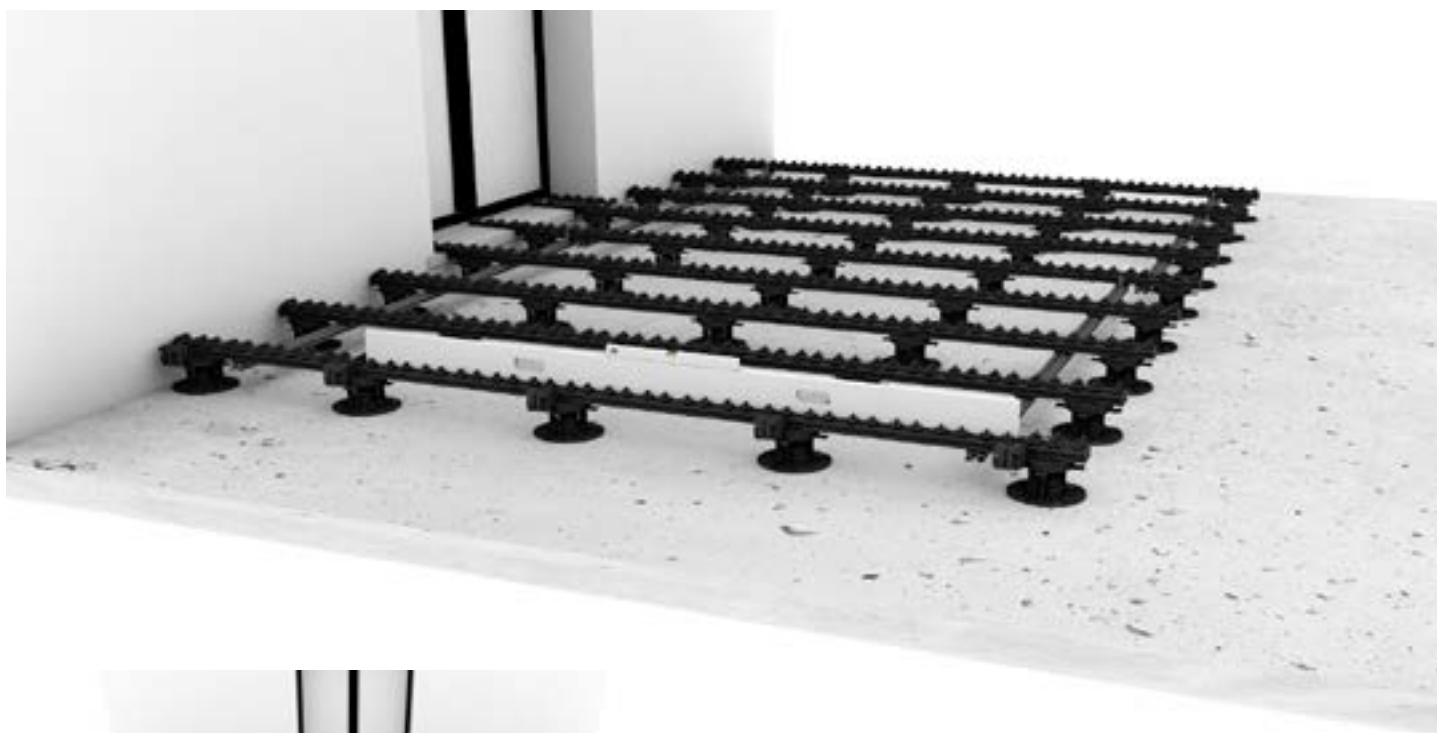
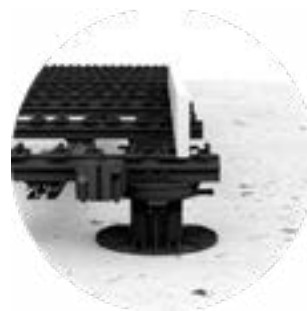

If diagonal 1 is equal to diagonal 2, then your structure is perfectly aligned.

Ensuring the structure is level

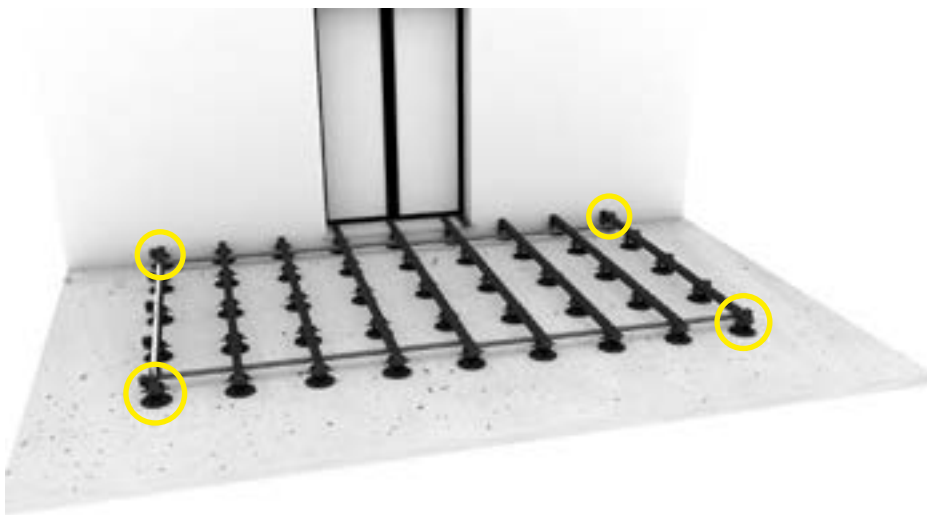
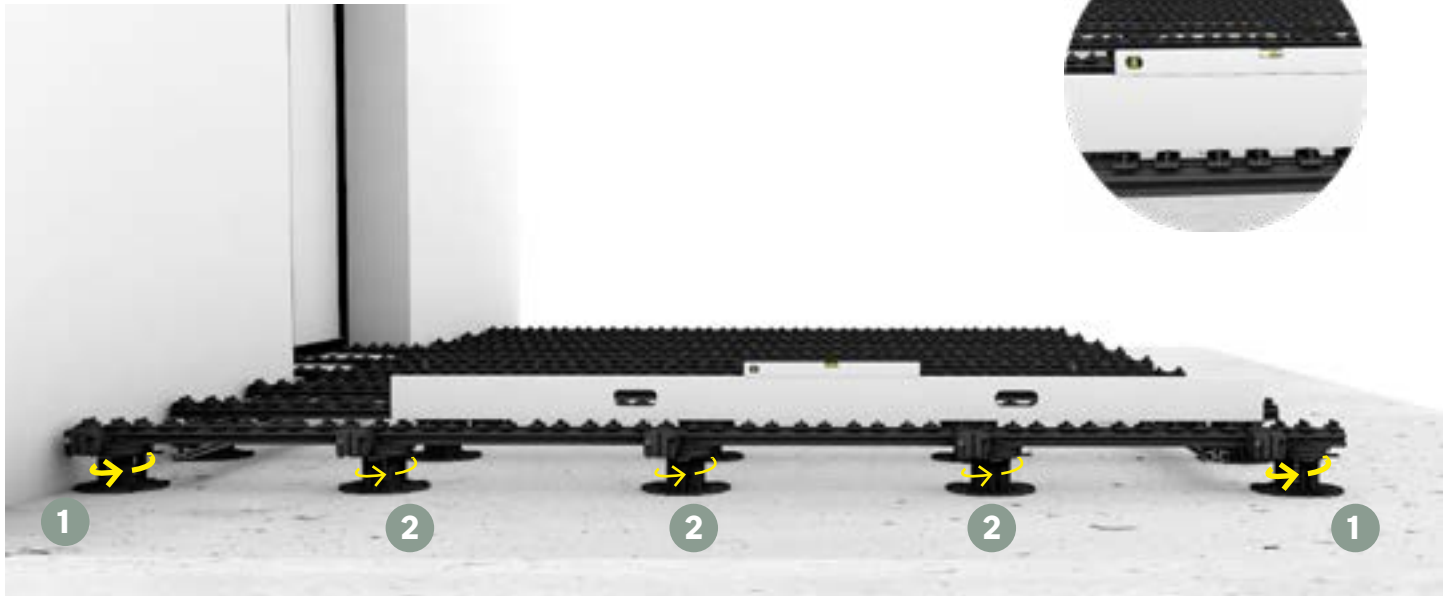

If the rails are not parallel to the supporting ground, first adjust the pedestals at the corners so that the structure is level. ① Then adjust all the other pedestals so that they are in contact with the ground. ②

 For boards featuring the curved comfort profile, the structure must be perfectly flat. For flat boards, the structure must have a 2% slope to allow water to run off.



Tighten the brackets and, if you have kept it and it reaches the ground, lower the Top Cube's mini-pedestal to the ground.

9 Prepare and mount the aluminium skirting

1. Marking

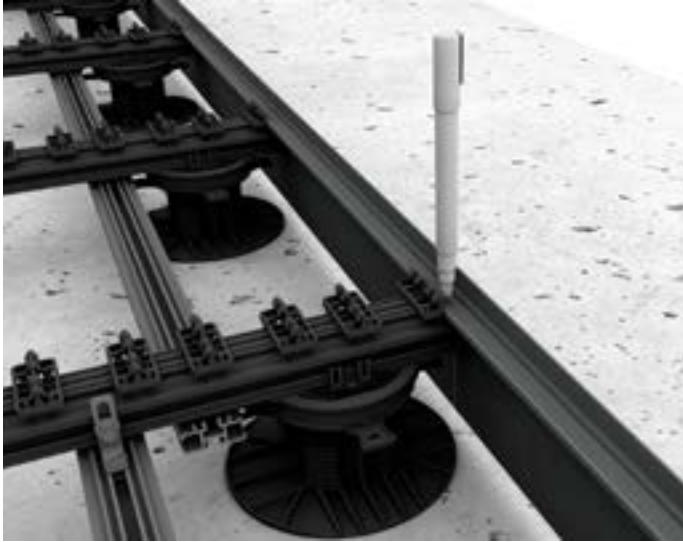

2. Drilling



To ensure that the holes are drilled in the right place, it is best to mark the skirting rail. The marking and drilling should be done in the groove of the skirting rail provided for this purpose (see illustration opposite). Depending on whether the rail is to be mounted to a Top Cube, the rail, or a rail junction, the marking/drilling must be done in the right place (see next page).

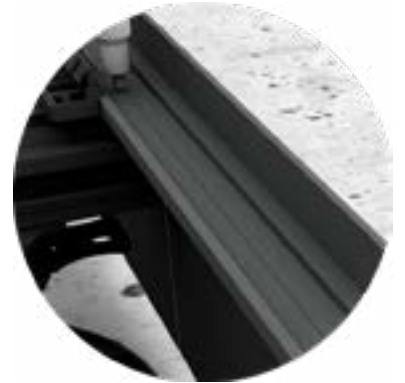

3. Cutting the skirting rails



If you wish to form a right angle, you will need to cut the edges of the strips at a 45° angle. To ensure an optimum finish, lightly file the cut to round it off.

20 INSTALLING THE ALUMINIUM SKIRTING

4. Mounting

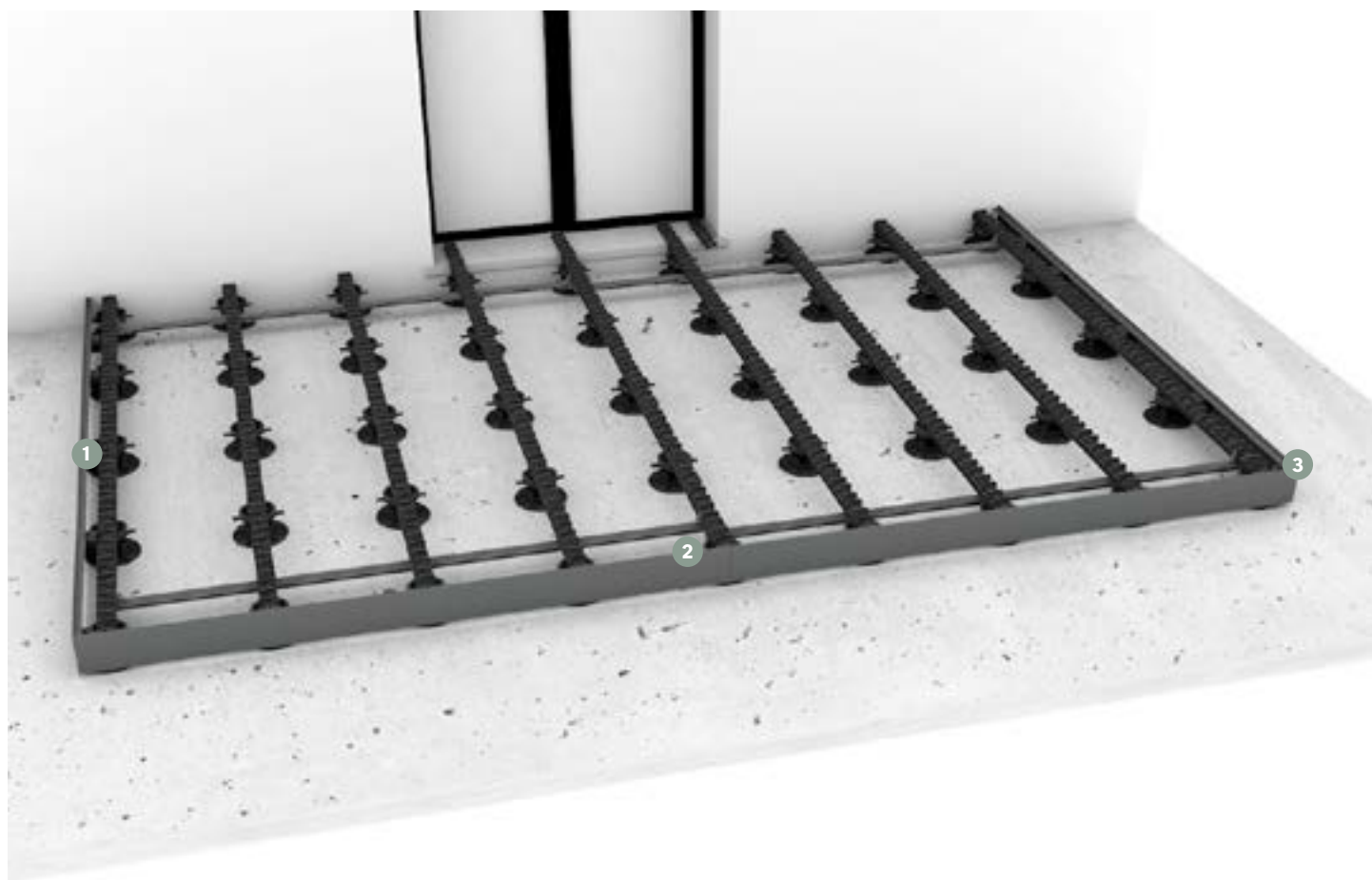

1 Side mounting on a Top Cube



 The Top Cube has recesses on its upper face to accommodate the fixing screws for the aluminium skirting.



① Simple Top Cube mounting

When the aluminium skirting rail rests entirely on the Top Cube, a single 4.8/38 mm stainless steel screw is required.



② Joining two skirting rails over a Top Cube

When two aluminium skirting rails are joined together, two 4.8/38 mm stainless steel screws secure the end of each skirting rail to the Top Cube.

21 INSTALLING THE ALUMINIUM SKIRTING

2 Mounting to the end of a rail

With 120 mm boards

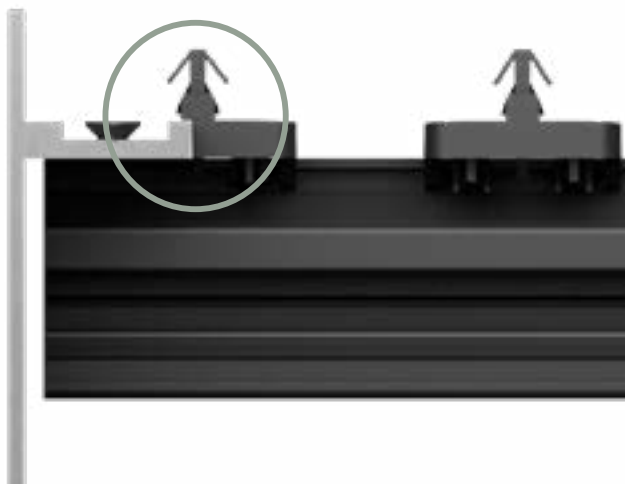

To install aluminium skirting correctly, the edge of the skirting must fit into the half-clip, as shown in the illustration above.

With boards over 120 mm

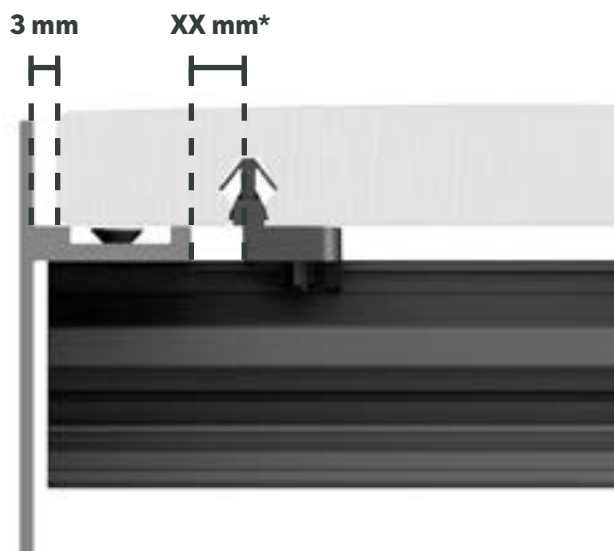

*Depending on the width of the board, the aluminium skirting rail cannot be fitted with the half-clip. The skirting rail must be offset by a few millimetres and screwed directly into the rail.



1 Simple lateral mounting

When the aluminium skirting rests entirely on the rail, a single M5/12 mm TF metal screw is required.

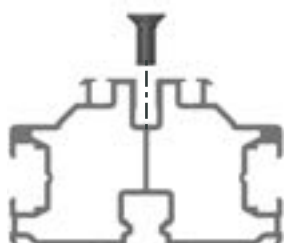

2 Joining two skirting rails

When two aluminium skirting rails are joined together, two 4.8/38 mm stainless steel screws secure the end of each skirting rail.

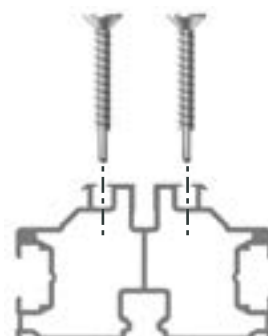

22 INSTALLING THE ALUMINIUM SKIRTING

3 Corner mounting

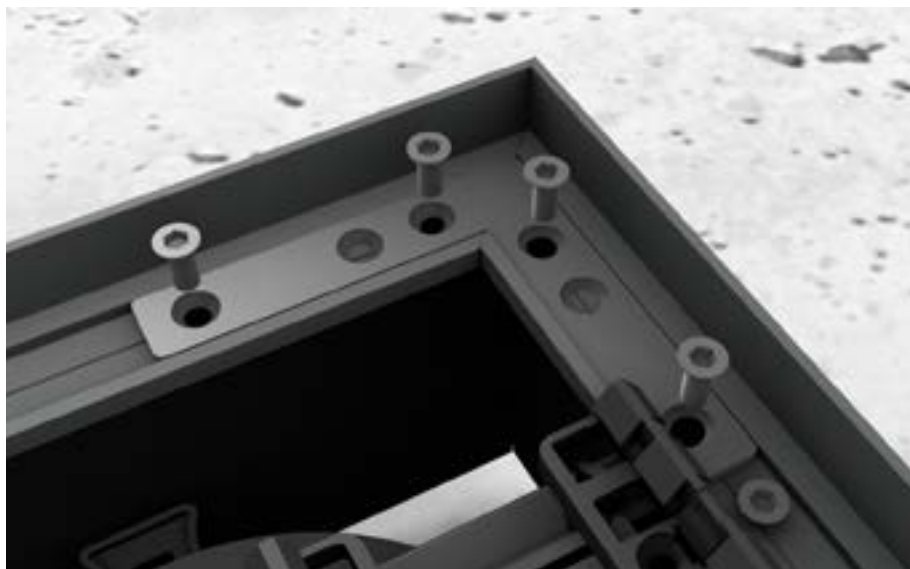

When pre-drilling the skirting, we recommend a diameter of 4 mm, followed by an M5 tap.

The use of a Top Cube in corners is not compatible with aluminium skirting fixed at a 90° angle. The screws are too long and will clash with the Top Cube.



Air circulation under the deck





To ensure optimal durability of your deck, a minimum gap of 2 cm is required between the bottom of the aluminum skirting and the supporting ground.* This space must also be free of any obstructions, such as soil or vegetation.

2 cm min.

*Refer to the installation recommendations of the decking board supplier (ventilation, landscaping, etc.).

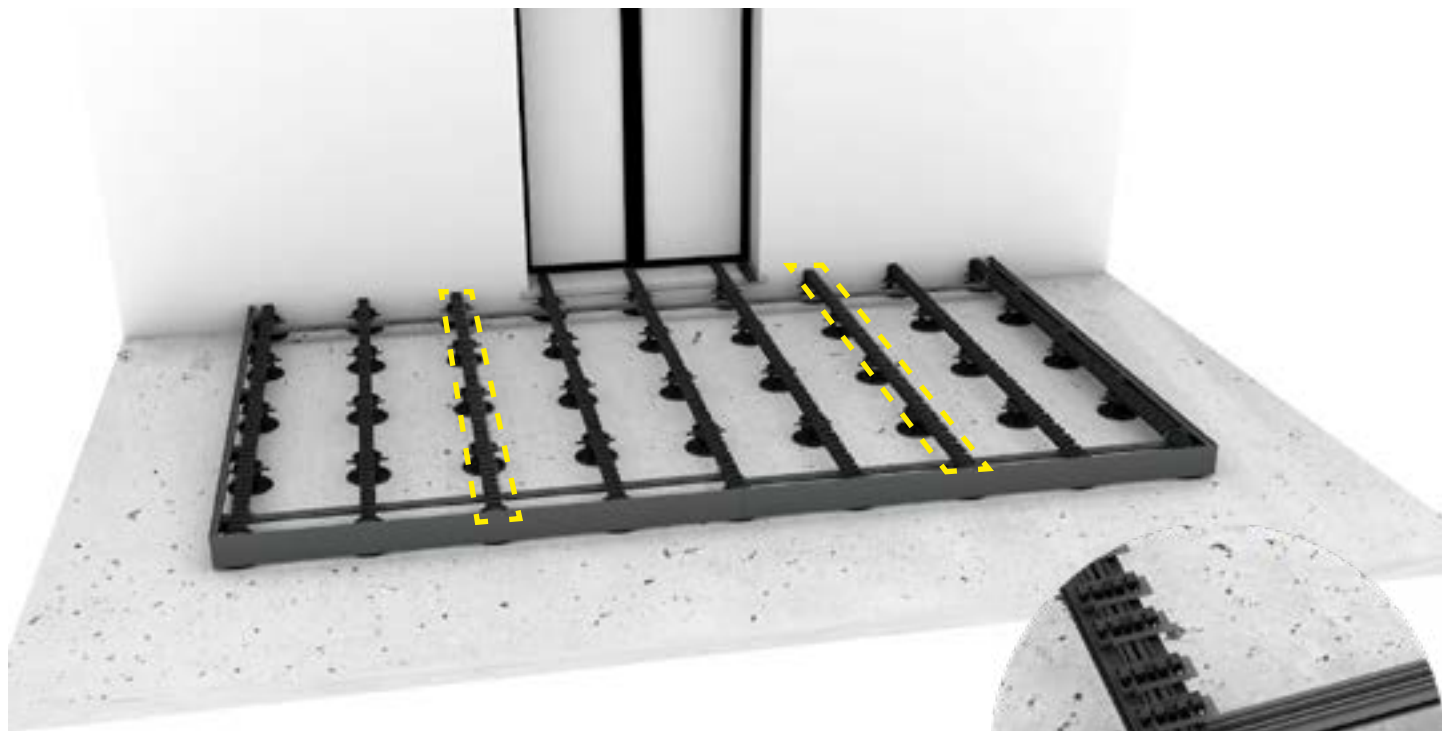
10 Add Clip Grips



 *Clip Grips are used to prevent the decking boards from shifting along the clips. They should be placed in the middle of the board.*

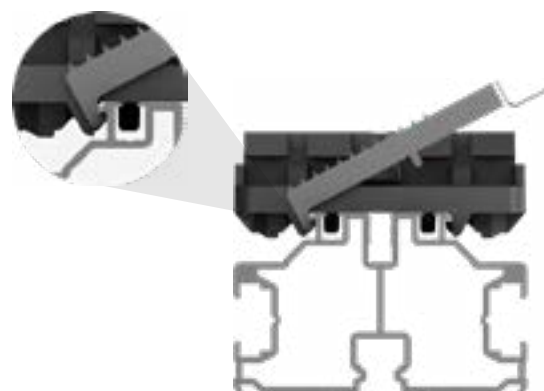
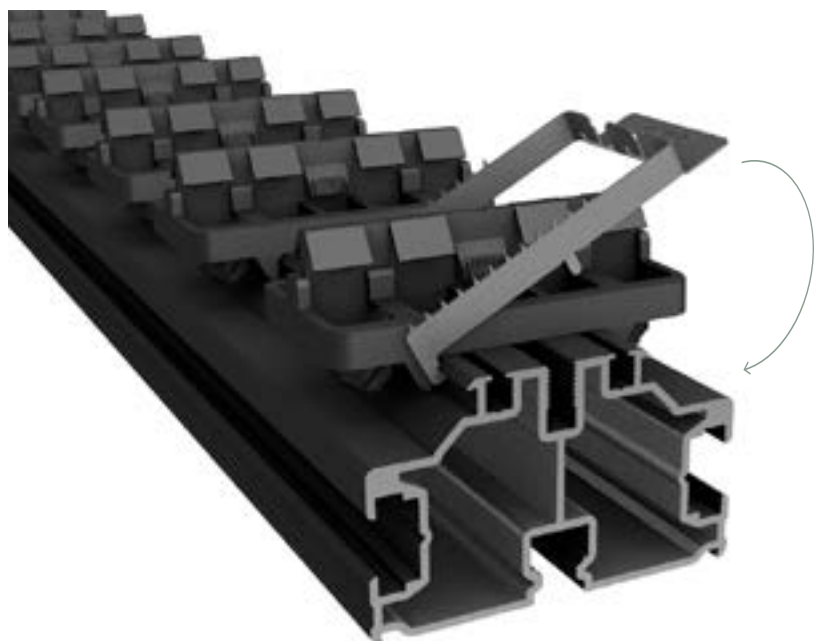

 *Clip Grips can only be fitted to removable clips. They are not compatible with half-clips.*



SCAN ME! 

11 Cutting and positioning the boards

Method 1: Marking, cutting and laying the boards

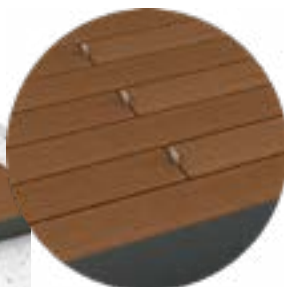
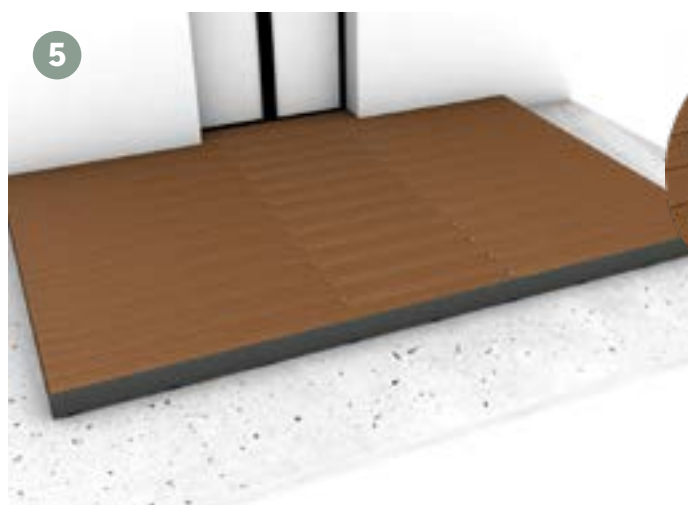
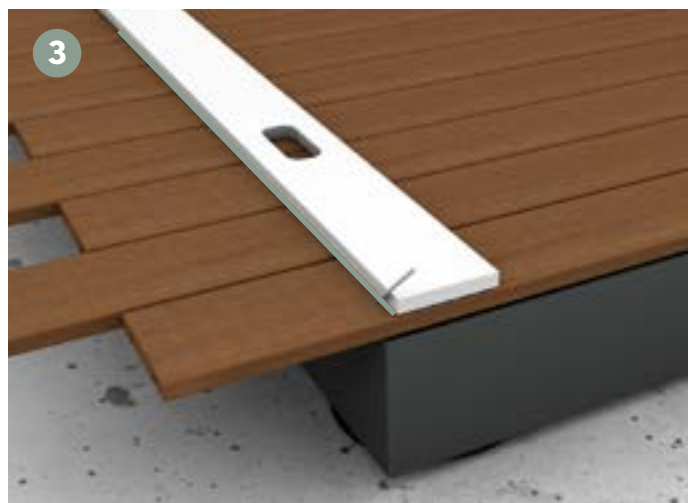
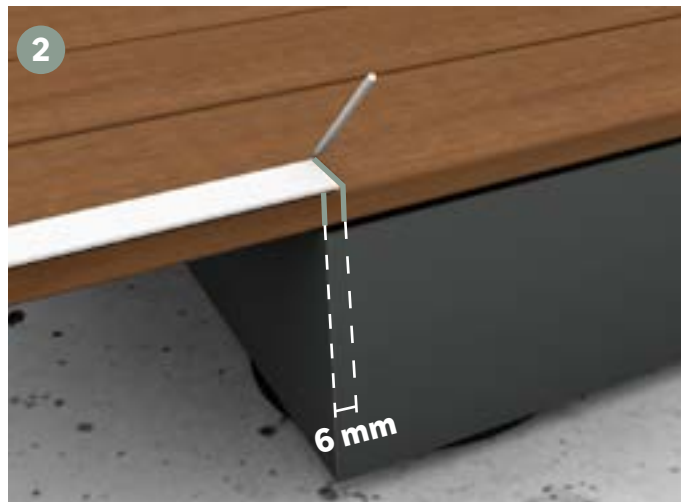

 Make sure the board joints are evenly spaced by placing a temporary spacer between the boards before they are clipped onto the rails

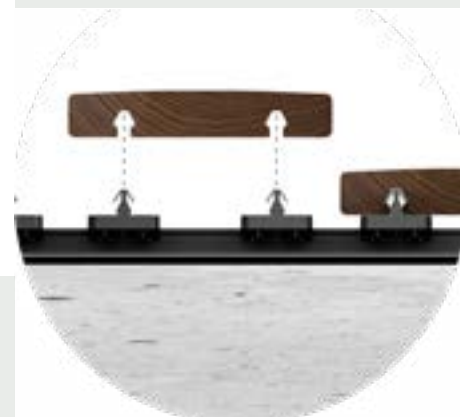

 After the boards are trimmed to size, simply position all the boards onto the clips and walk on them to attach them to the clips. Do not use hammers or other tools that could damage the boards.

25 POSITIONING AND INSTALLING THE DECKING BOARDS

Method 2: Measure the width of the deck

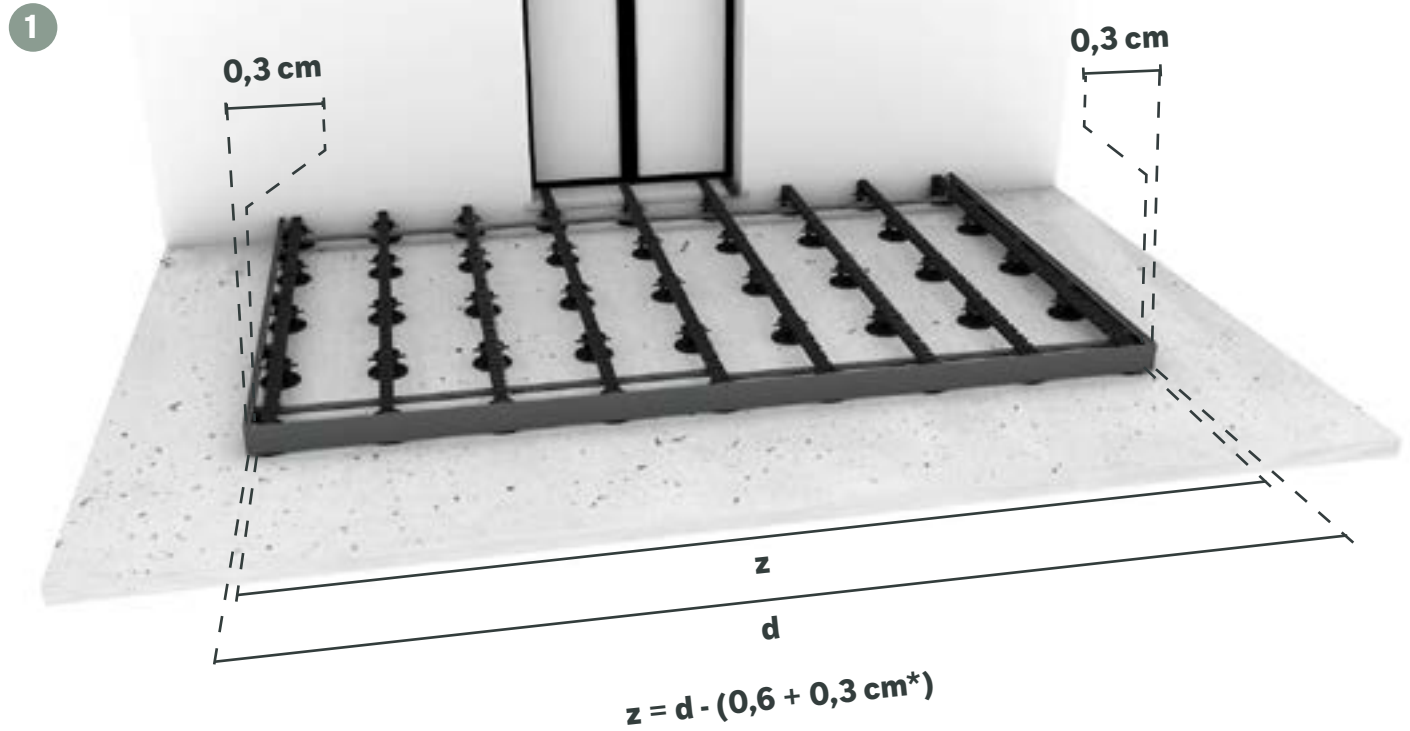

To calculate the correct distance to cut the boards, simply measure the distance between each aluminium skirting rail and subtract 6 mm for the edges, plus 3 mm if the boards are to be butt-jointed (*).

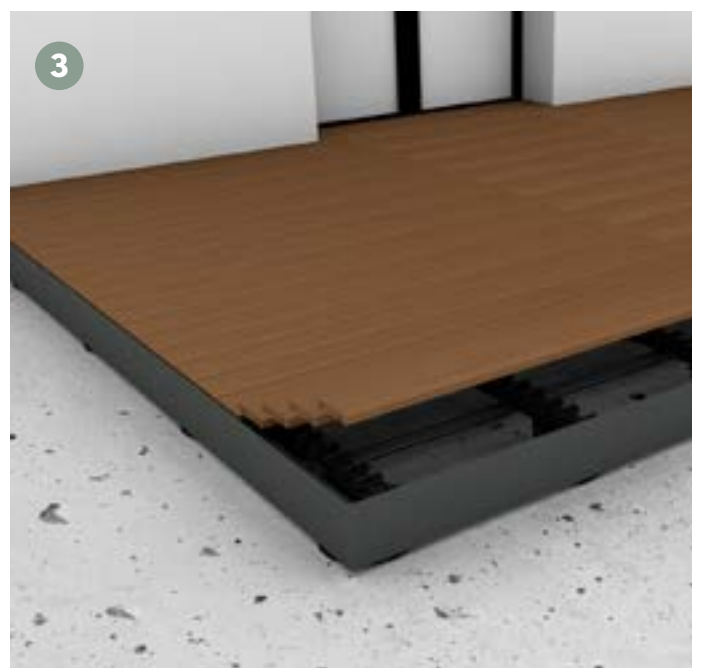

26 POSITIONING AND INSTALLING THE DECKING BOARDS

Good practice for butt joints

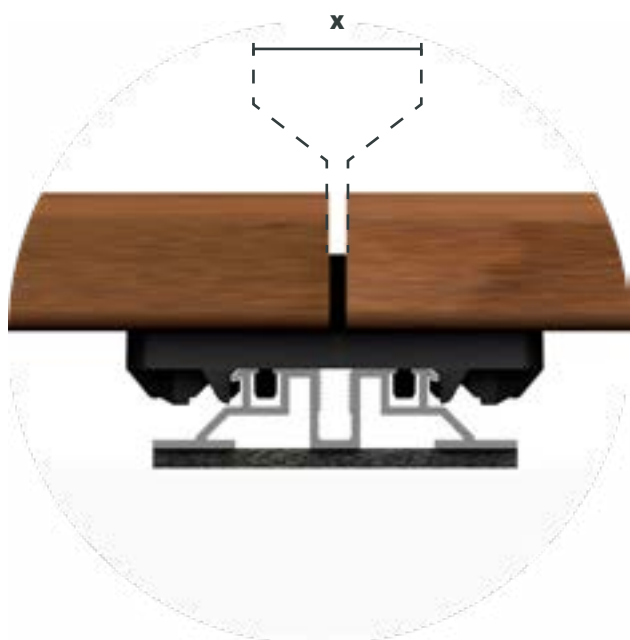

The boards must be butt-jointed over a clip.

Reminder for butt joints

	x
MOSO® boards	0 mm
Other wooden boards	3 mm
Composites and aluminium	Variable

The space between the butt joints of composite and aluminium boards depends not only on the manufacturer's requirements, but also on the temperature at the time of installation and the length of the boards.

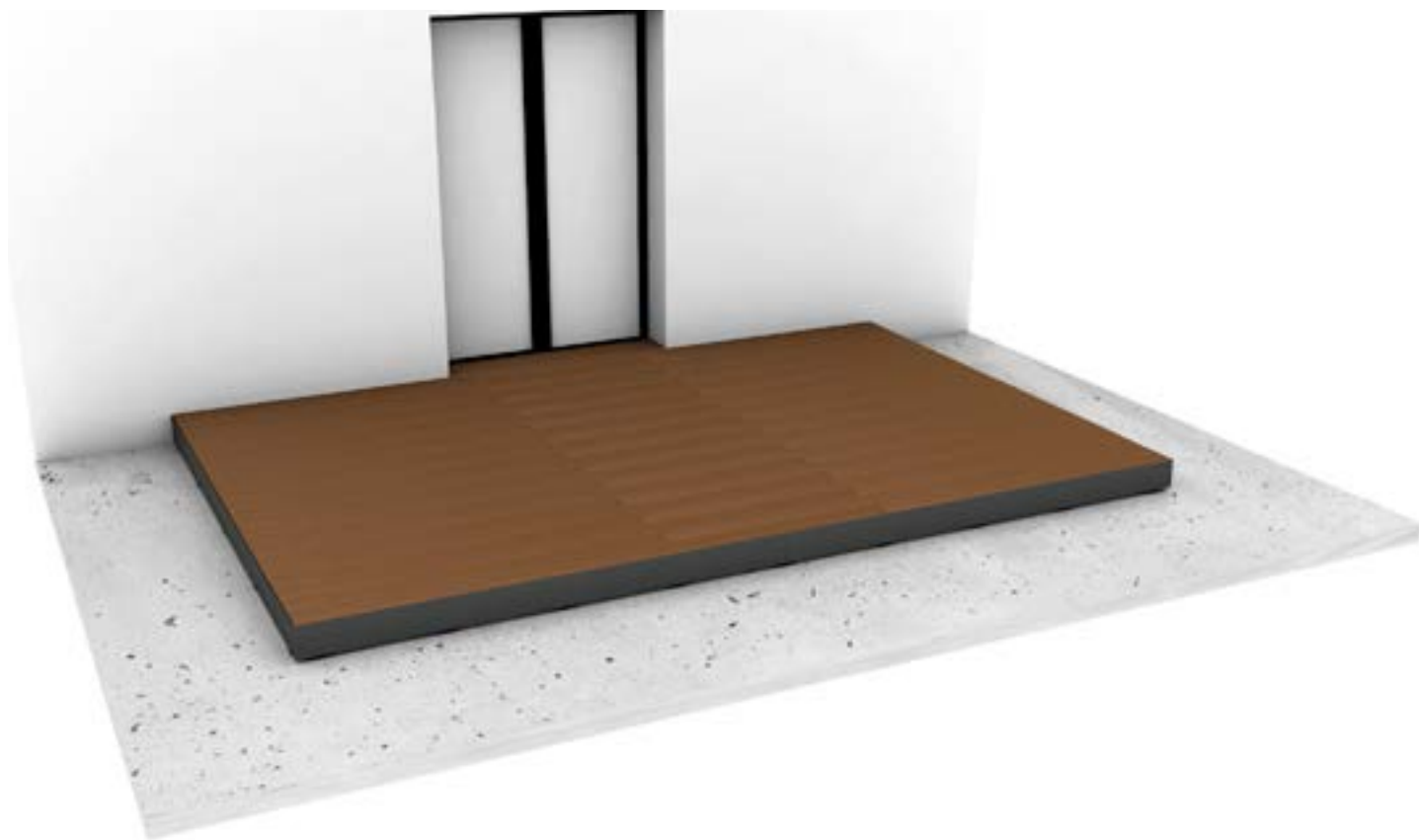

Congratulations! The installation of your PR39 or PR56 rail-mounted decking with aluminium skirting is now complete!

 Please note that if you want to install a spa, jacuzzi or brazier, for example, these items must never rest directly on the deck. They must rest on a specific support that is separate from the structure of your deck.

HOW TO EASILY REMOVE DECKING BOARDS

Unclipping boards

Follow the instructions below to remove your deck boards easily and without damage.



28 REMOVING A BOARD



Dismantling Keys

One of Grad®'s strengths also lies in the fact that you can remove the boards from your deck quickly and easily using the specially designed Dismantling Keys.



Depending on the width of the boards, one pair of keys is more suitable than the other. Make sure your decking matches the keys before placing your order.



1 Start at the end of the board

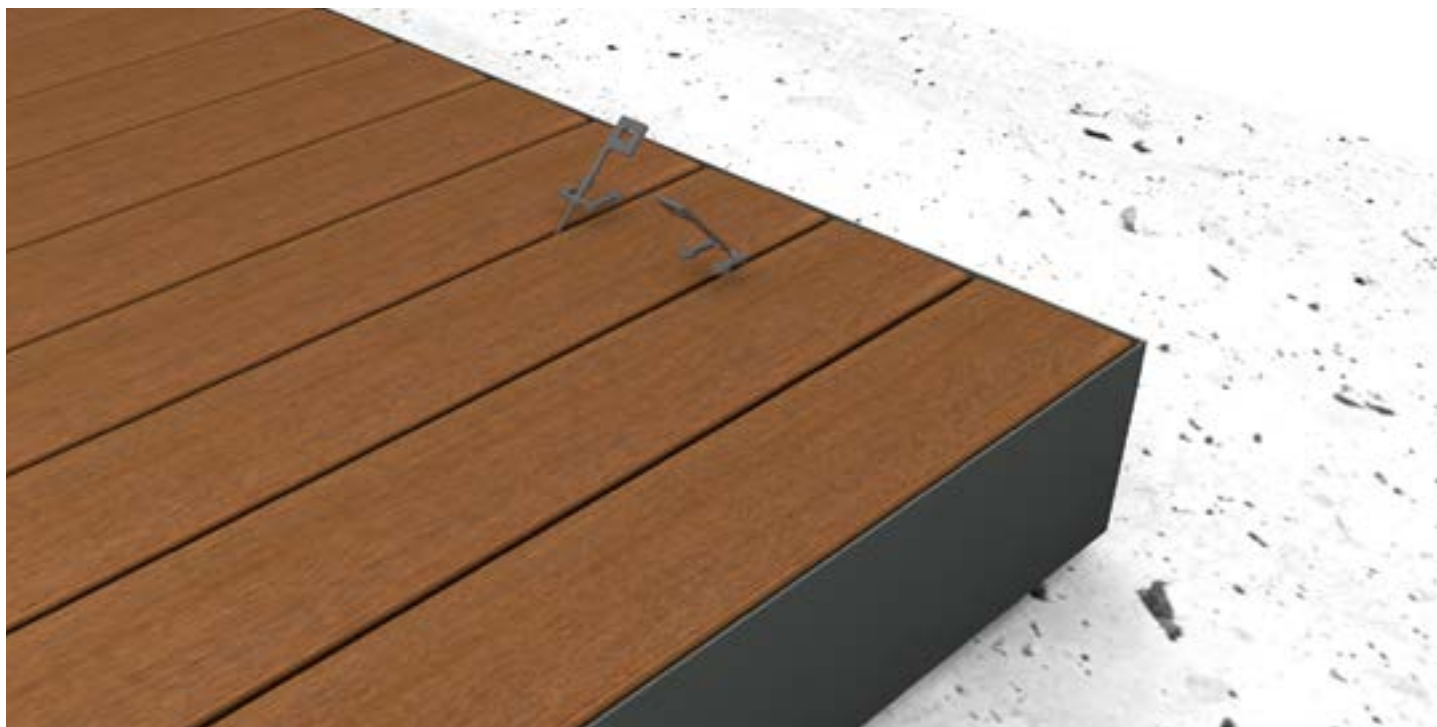

Unclip the board starting at one end, then at each intersection between the rail and the board until you reach the other end of the board.



It is impossible to unclip a board from the middle.

29 REMOVING A BOARD

2 Insert the keys between the boards

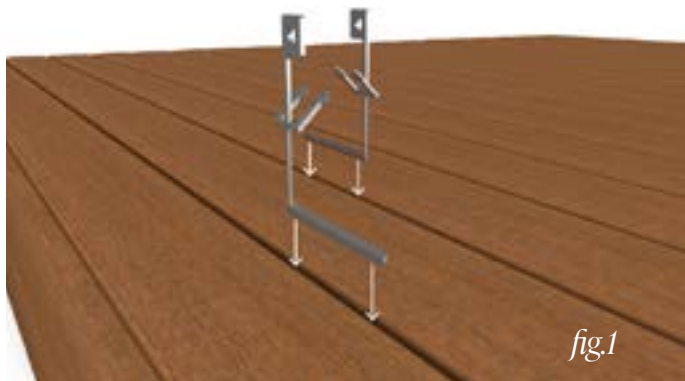

Place the keys parallel to the board and perpendicular to the rail (*fig. 1*).

3 Turn the keys

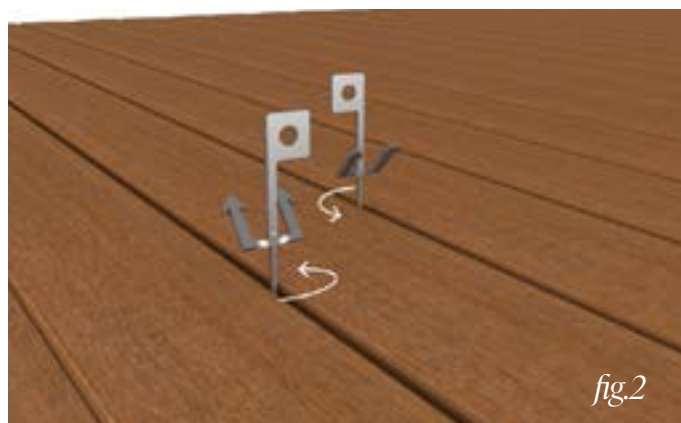

Turn the keys 90° counterclockwise so that the lower part of the keys is parallel to the rail (*fig. 2*).

4 Tilt the keys



Tilt the keys and slide them in the direction of the arrows until they touch the rail and grip the clips. The keys are correctly positioned. (*fig. 3*)

5 Apply pressure to the keys

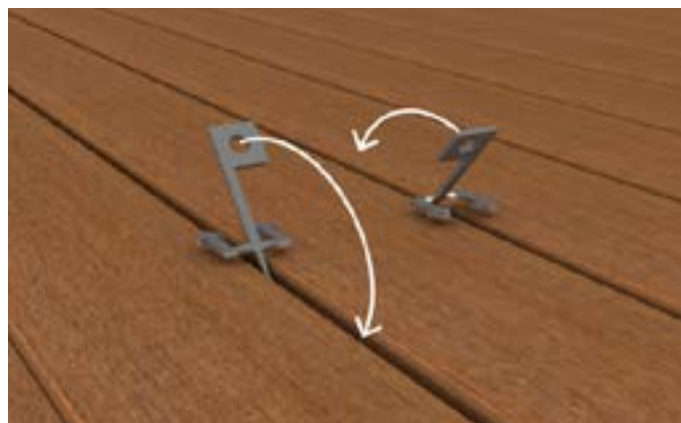

Apply pressure to the keys so that the lower part of the keys unclips the clips from the rail. When the board is fully unclipped, turn it over and carefully slide the clips out of the grooves. All that remains is to reclip the clips to the rail.

 In the case of projects using PR39 rails, the keys may come into conflict with the pedestal boosters; in this case, remove the neighbouring board first.

 Although it is possible to unclip the boards from your deck, we recommend that you only do so on rare occasions.

GRAD® - BURGER & CIE

Z.I. Bois l'Abbesse
68660 LIÈPVRE - FRANCE
+33(0)3 89 58 45 45

GRAD-SYSTEM.COM

