

## TOP LINK

Utilisation : pièce d'aboutage de rails de terrasse et de bardage



Réf. 2784  
**Top Link 46**



Réf. 2785  
**Top Link 51**



Réf. 1488  
**Top Link 56**

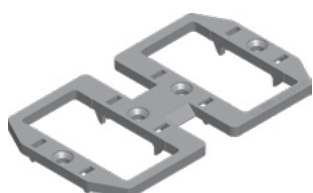

Réf. 1489  
**Top Link 71**

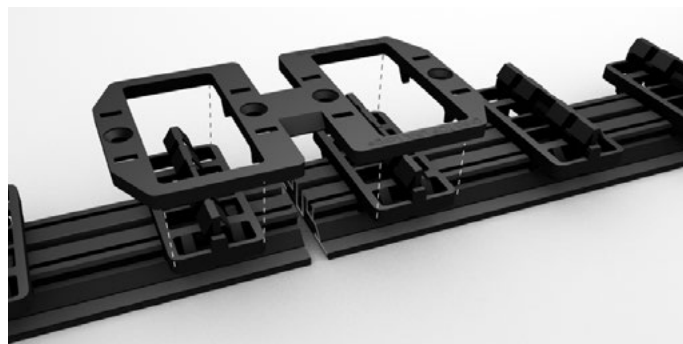

TOP LINK	46	51	56	71
Référence	2784	2785	1488	1489
Matière	POM (Polyoxyméthylène)			
Poids	16,86 g	17,72 g	20,22 g	22,18 g
Dimensions	102 x 74 x 5 mm	107 x 74 x 5 mm	112 x 74 x 5 mm	127 x 74 x 5 mm
Couleur	Noir			
Conditionnement	20 pcs			

## INSTALLATION

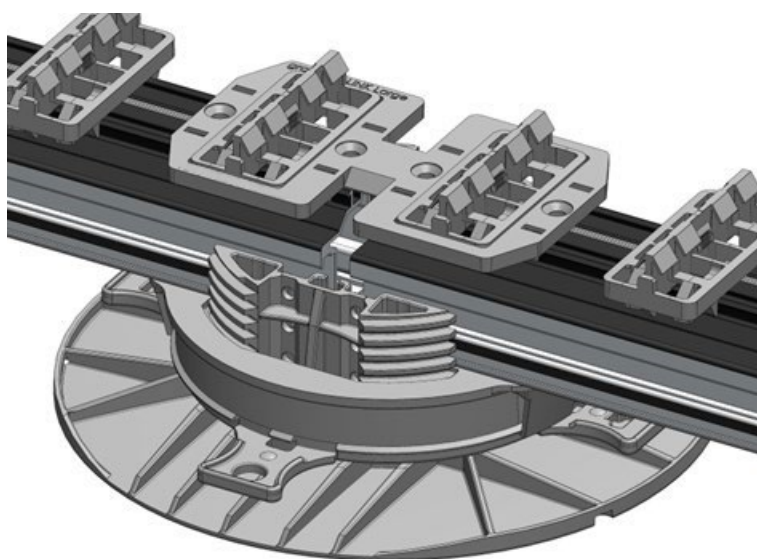
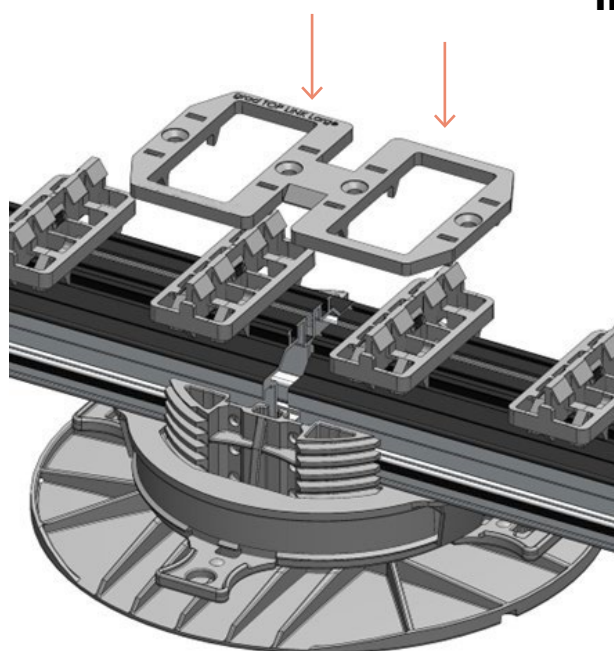

## DIMENSIONS

TOP LINK 46

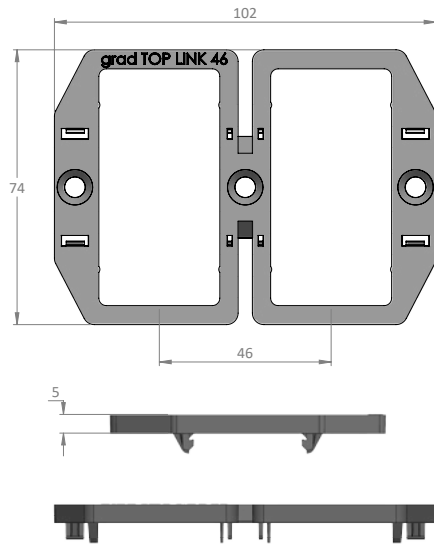

TOP LINK 51

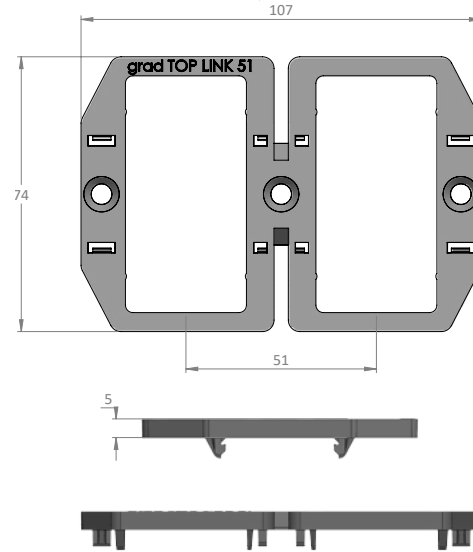

TOP LINK 56

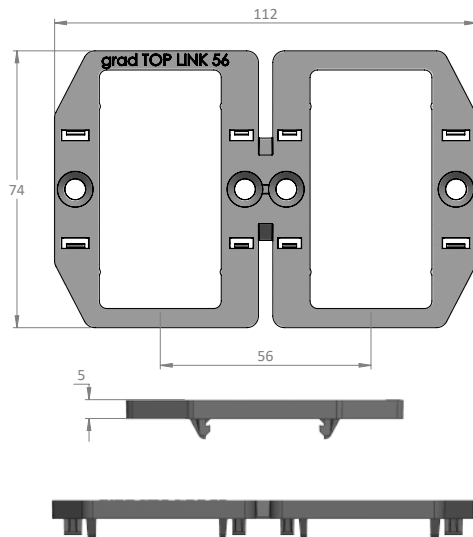

TOP LINK 71

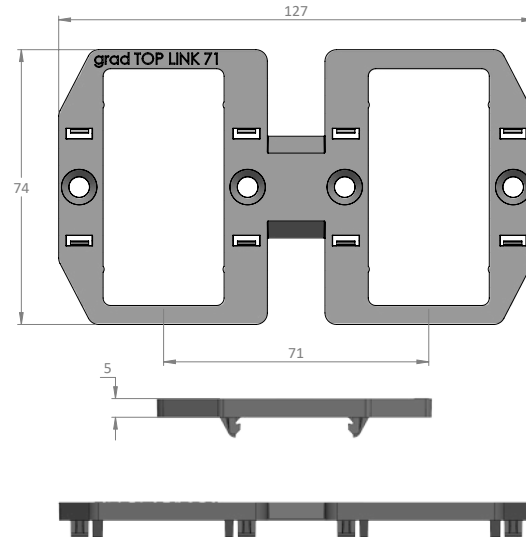

## DÉMONTAGE

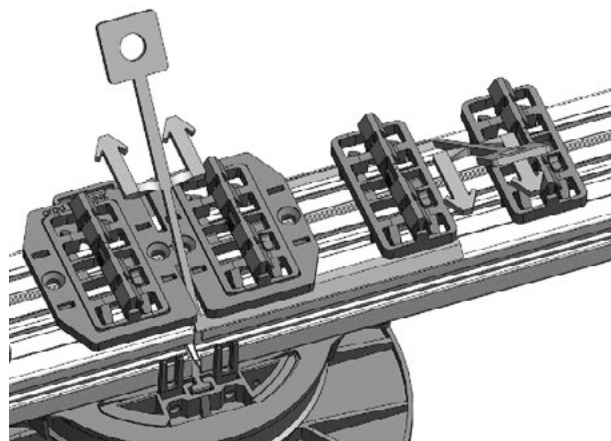

## COMPATIBILITÉ

### CAS POUR LAMES AVEC 1 RAINURE

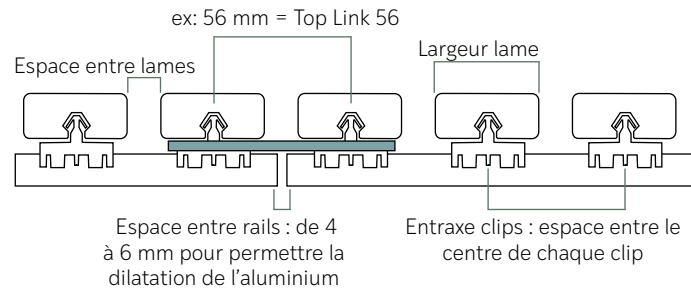

### CAS POUR LAMES AVEC 2 RAINURES

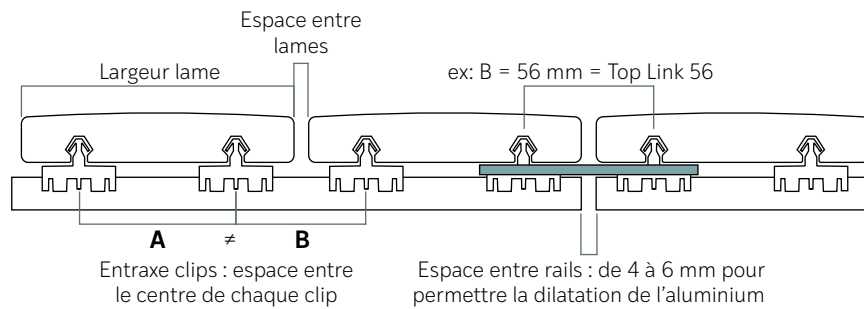

### COMPATIBILITÉ TOP LINK + RAILS

	TOP LINK 46 2784	TOP LINK 51 2785	TOP LINK 56 1488	TOP LINK 71 1489
<b>MINI RAIL</b>		1635	2171	2173
<b>START RAIL</b>		2120	1687 2135 2495	1902
<b>FLAT RAIL</b>	2191	1799	1185 1188 2222 2236 3319	1187 1800 1862 1868 2031 2237 2238 2800
<b>PR24</b>			1191 1997 2588 2587	1801 1970 2033 3279
<b>TOP RAIL</b>			1189 3307	1971 1808 2032 1190
<b>PR39</b>			1194 1478 1602 2510 3226 3309	1195 1802 2034 2093
<b>PR56</b>			1197 2062	1803 1972 2035 3280